

DATE	MILEAGE FOR LOCAL ROADS/STREETS	LOCAL ROADS/STREETS	
		Certified in accordance with sec. 86.30 Wis. stat.	
(1) 4-1-11	189.71	Name:	Title:
(2) 1-1-12		Signature:	Date:
(3) 4-1-12			

MILEAGE FOR COUNTY TRUNKS	MILEAGE FOR COUNTY OTHER ROADS
00.00	00.00

- (1) THIS DATA REPRESENTS THE LAST CERTIFIED MILEAGE AS CORRECTED BY WISDOT WHICH MAY HAVE BEEN USED FOR PAST TRANSPORTATION AIDS.
- (2) THE TOWN CHAIRMAN OR CITY/VILLAGE CLERK IS TO FILL IN THE MILEAGE TO BE CERTIFIED AS OPEN TO THE PUBLIC AS OF THE FOLLOWING JANUARY, INCLUDING THE NEW CHANGES THAT ARE MADE ON THE PLAT.
- (3) THIS DATA REPRESENTS MILEAGE ADJUSTMENTS MADE BY WISDOT DUE TO FIELD VERIFICATION, INVENTORY, ANNEXATION, ETC. TRANSPORTATION AID PAYMENTS MAY BE MADE BASED ON THIS FIGURE.

CITY OF  
**SUPERIOR**  
COUNTY: DOUGLAS



LEGEND:

Local Road	State On/Off Ramp	PLSS Border
Park Road-Local	US Connecting Highway	Bridge
Interstate Highway	State Connecting Highway	Gate
US Highway	Railroad	
State Trunk	CVT Border	

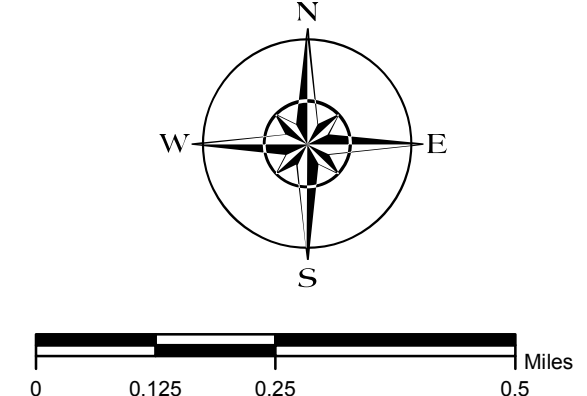

This information contained on this map was created for the official use of the Wisconsin Department of Transportation (WisDOT). Any other use while not prohibited, is the sole responsibility of the user. WisDOT expressly disclaims all liability regarding fitness of use of the information for other than official WisDOT business.