

STATE OF WISCONSIN
WISCONSIN DEPARTMENT OF TRANSPORTATION
TOWN PLAT RECORD

TOWN OF
SUMMIT
COUNTY: DOUGLAS

| DATE | MILEAGE FOR LOCAL ROADS/STREETS | LOCAL ROADS/STREETS | |
|--|---------------------------------|---------------------|--------|
| Certified in accordance with sec. 86.30 Wis. stat. | | | |
| (1) 4-1-17 | 87.10 | Name: | Title: |
| (2) 1-1-18 | . | Signature: | Date: |
| (3) 4-1-18 | . | | |

| MILEAGE FOR COUNTY TRUNKS | MILEAGE FOR COUNTY OTHER ROADS |
|---------------------------|--------------------------------|
| 23.65 | 00.00 |

- (1) THIS DATA REPRESENTS THE LAST CERTIFIED MILEAGE AS CORRECTED BY WISDOT WHICH MAY HAVE BEEN USED FOR PAST TRANSPORTATION AIDS.
- (2) THE TOWN CHAIRMAN OR CITY/VILLAGE CLERK IS TO FILL IN THE MILEAGE TO BE CERTIFIED AS OPEN TO THE PUBLIC AS OF THE FOLLOWING JANUARY, INCLUDING THE NEW CHANGES THAT ARE MADE ON THE PLAT.
- (3) THIS DATA REPRESENTS MILEAGE ADJUSTMENTS MADE BY WISDOT DUE TO FIELD VERIFICATION, INVENTORY, ANNEXATION, ETC. TRANSPORTATION AID PAYMENTS MAY BE MADE BASED ON THIS FIGURE.

| DATE | COUNTY FOREST ROAD MILEAGE | COUNTY FOREST ROADS | |
|---|----------------------------|---------------------|---|
| Certified in accordance with sec. 86.315 Wis. stat. | | | |
| (4) 4-1-17 | DNR APPROVED | 19.18 | Signature: _____ Date: _____ |
| (5) 1-1-18 | DNR APPROVED | . | |
| (6) | ELIG TRANS AIDS | . | County Forest Administrator Name: _____ |
| (7) | NOT ELIG TRANS AIDS | . | |

- (4) THIS DATA REPRESENTS THE MILEAGE REPORTED LAST CERTIFICATION YEARS BY THE COUNTY FOREST ADMINISTRATOR.
- (5) THE COUNTY FOREST ADMINISTRATOR IS TO FILL IN MILEAGE TO BE CERTIFIED AS COUNTY FOREST ROADS THAT ARE OPEN TO THE PUBLIC AS OF THE FOLLOWING JANUARY, INCLUDING NEW CHANGES THAT ARE ADDED TO THE COUNTY FOREST ROAD SYSTEM.
- (6) THIS IS TO BE FILLED IN BY WISDOT, AFTER THE SURFACE AND ROADWAY WIDTHS HAVE BEEN REVIEWED TO DETERMINE ELIGIBILITY FOR TRANSPORTATION AIDS.
- (7) THIS DATA REPRESENTS DNR COUNTY FOREST ROADS MILEAGE THAT IS NOT ELIGIBLE FOR TRANSPORTATION AIDS.

TOWN OF SUPERIOR

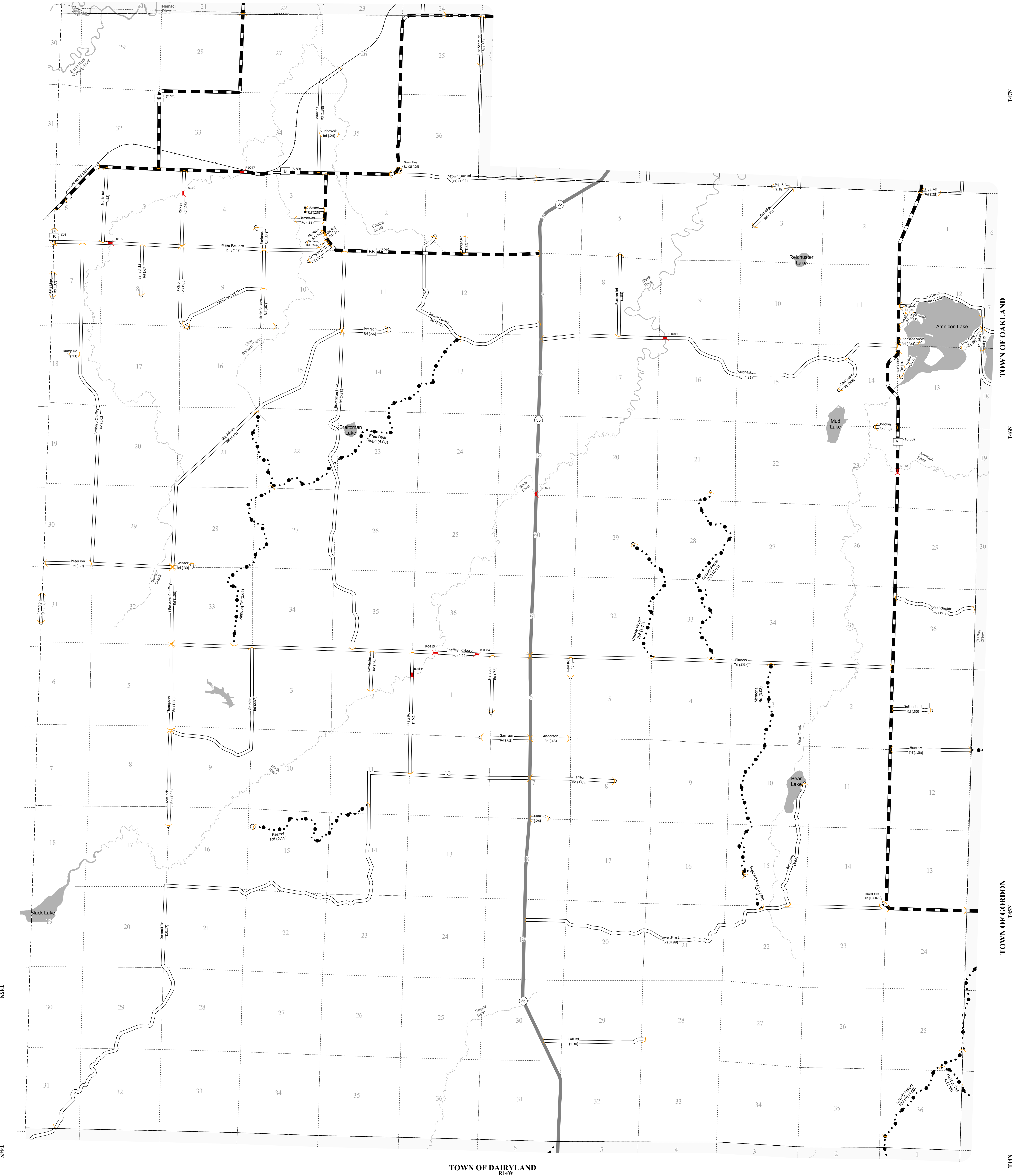

LEGEND:

- County Trunk Highway
- Local Road
- County Forest - Eligible
- State Trunk
- Railroad
- CVT Border
- PLSS Border
- Bridge
- Gate
- Route Identifier

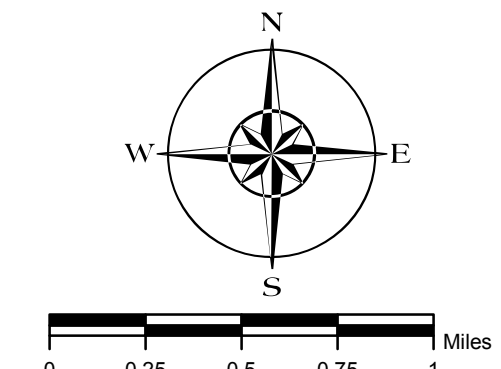

The information contained on this map was created for the official use of the Wisconsin Department of Transportation (WisDOT). Any other use without the express permission of the user. WisDOT expressly disclaims all liability regarding fitness of use of the information for other than official WisDOT business.