

LEVELS ON = 1, 2, 3, 4, 5, 6, 7, 8, 9, 10, 11, 12, 13, 14, 15, 16, 17, 18, 19, 20, 21, 22, 23, 24, 25, 26, 27, 28, 29, 30, 31, 32, 33, 34, 35, 36, 37, 38, 39, 40, 41, 42, 43, 44, 45, 46, 47, 48, 49, 50, 51, 52, 53, 54, 55, 56, 57, 58, 59, 60, 61, 62, 63

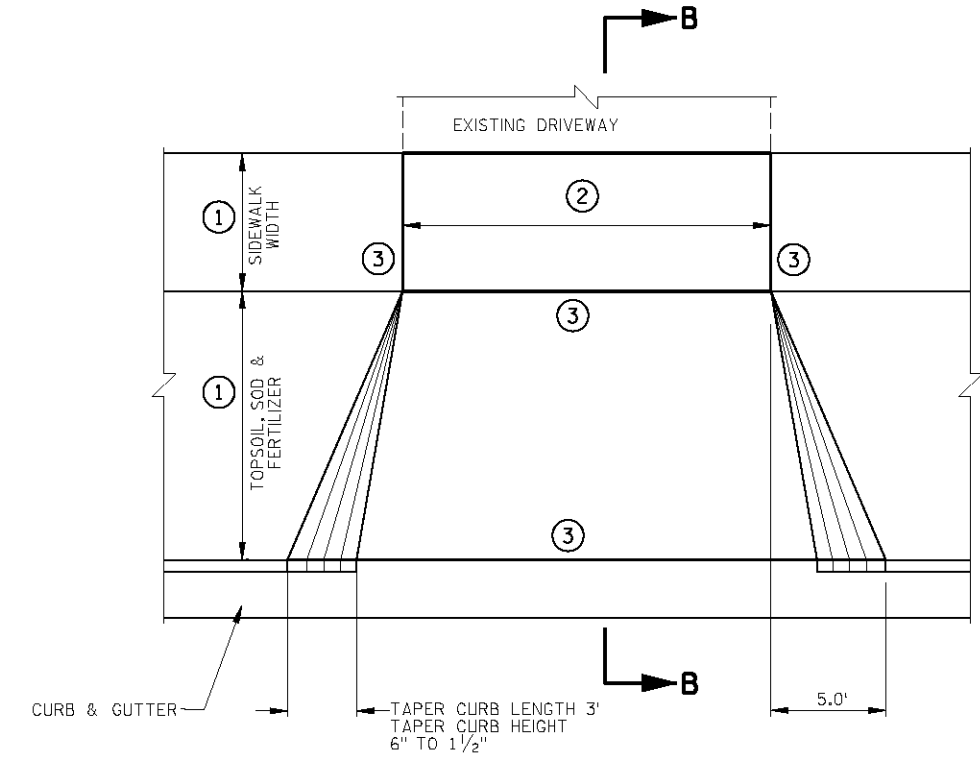
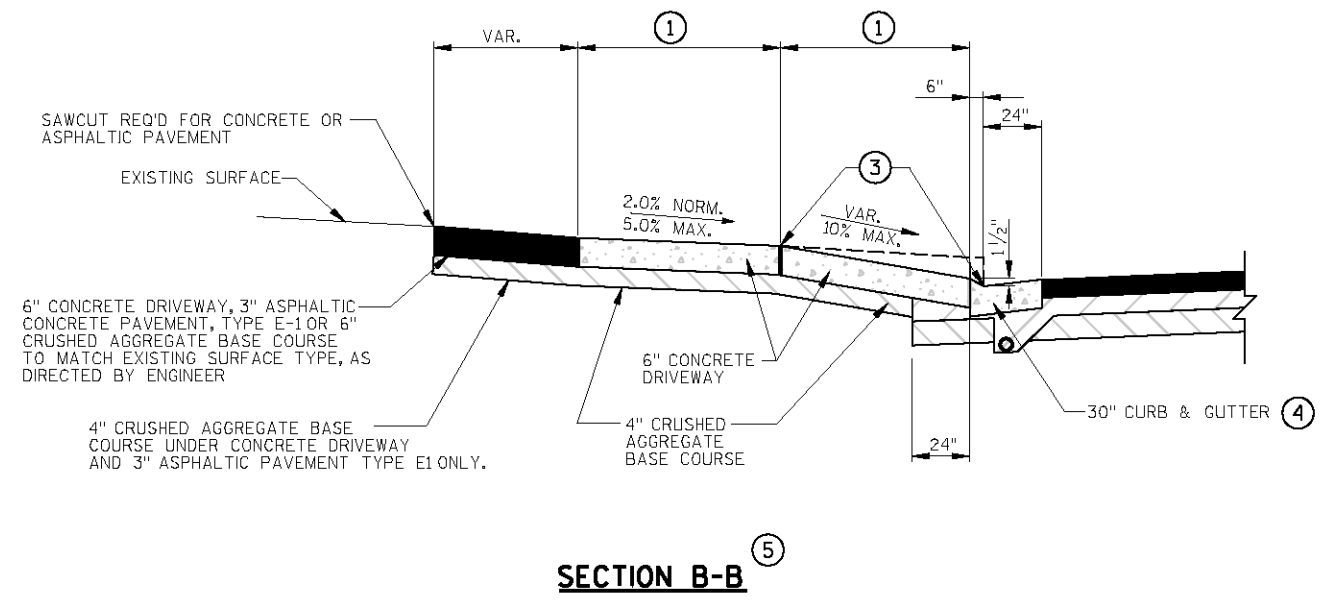

- NOTES:
- ① SEE TYPICAL SECTIONS FOR SIDEWALK AND TERRACE WIDTHS.
 - ② SEE PLAN/PROFILES FOR DRIVEWAY WIDTHS.
 - ③ 1/2" PREFORMED EXPANSION FILLER BETWEEN CURB AND NEW SIDEWALK AND BETWEEN NEW SIDEWALK AND EXISTING SIDEWALK AND EXISTING CONCRETE DRIVEWAY.
 - ④ SEE TYPICAL SECTIONS FOR CURB TYPE.
 - ⑤ SEE TYPICAL SECTIONS FOR PLACEMENT OF GEOTEXTILE FABRIC.