



# Executive Summary

## Superior Connect Fiber Network Equipment and Services

October 3, 2023

### **Adtran PROPRIETARY**

**This document is the property of Adtran Inc. Any duplication, reproduction, or transmission to unauthorized parties without the permission of Adtran Inc. is prohibited.**

**This document represents a proposed solution for a specific application. Specific requirement implementation is conditional depending on customer approval of the solution and a mutually agreed upon development schedule.**

**Copyright © 2023 Adtran Inc.**

**ALL RIGHTS RESERVED**

## Executive Summary

As a long-standing, trusted partner for network operators across the globe, Adtran is a leading global provider of open, disaggregated networking and communications solutions that enable voice, data, video and internet.

Adtran is the best choice for service providers looking for a flexible, cost-effective solution to evolve their networks and deliver a wide range of next-generation services.

On August 30, 2021, we announced our now executed business combination with ADVA to create a global leader in scalable, end-to-end fiber networking solutions for communication service providers, enterprises, and government customers. The merger unites our fiber access, fiber extension, and subscriber connectivity technology with ADVA's innovation in data center interconnect solutions for large enterprises, business Ethernet and network synchronization. Both companies are pioneers in open, disaggregated solutions with a shared vision for the future of fiber networking. Our combined business offers a comprehensive portfolio for providing homes, businesses and 5G infrastructure with scalable, secure and assured fiber connectivity, paired with cloud-managed Wi-Fi connectivity and SaaS applications. Together we are a trusted supplier to more customers worldwide, meeting new requirements, optimizing network performance, and improving customer experience.

## Proposed Solution

Adtran has thoroughly assessed the Network and Services Request for Proposal (RFP) from Superior Connect. Our dedicated response team is delighted to present our comprehensive solution outlined in the attached documents. Our proposal is carefully crafted to not only meet but exceed Superior Connect's expectations, ensuring the enhancement of their reputation upon the introduction of this new service to the community.

Adtran's proposal stands out by offering the most cost-effective ownership solution, empowering superior customer service capabilities, and simplifying internal operations in comparison to any alternative available.

With this mind, the foundation of our proposal is Mosaic One, which Adtran developed by listening to our customers and responding with what combines the most comprehensive Subscriber Network Management tools in the industry.

Modern broadband networks must deliver more than high-speed connections – they must deliver an optimized customer experience powered by value-driving applications. Mosaic One is a cloud-based Software as a Service (SaaS) that aggregates AI-driven insights from network management and service orchestration applications pulling data from access network platforms and in-home devices. The result is actionable intelligence leveraged from network and user behavior insights presented in three distinct dashboard portals: **Care**, **Operate** and **Promote**.

- **Mosaic One Care** enables support teams to access a unified view of a customer's experience and utilize actionable intelligence to resolve customer issues on the first call, improving satisfaction and reducing costly escalation.

- **Mosaic One Operate** equips network engineering and maintenance teams with AI- driven insights to preemptively identify at-risk connections and alarms, reduce truck rolls, and minimize network downtime.
- **Mosaic One Promote** empowers marketing teams to easily leverage customer insights, advanced filters, and marketing platform integrations. This knowledge allows Marketers to target the right customer with the right service campaign every time.

Unlike other siloed solutions on the market, Mosaic One has all three areas of focus under a single unified view, hence the "One" in Mosaic One. It helps you with customer care, network resilience, and customer loyalty, with intelligence only from Adtran, backed by three decades of expertise. Mosaic One equips service providers to excel in the areas of business that matter most.

Our Mosaic One proposal includes three additional Adtran Services starting with an Onboarding Team that will guide Superior Connect through the installation and initial training. When onboarding is complete, a Customer Success Manager (CSM) will be assigned to Superior Connect to make sure you are utilizing all the features of Mosaic One and getting the full value from your investment. Finally, Adtran's US based 24/7/365 Customer Support Team will join the CSM to support Superior Connect for lifetime of your Mosaic One subscription. All three additional services are included in Adtran's proposal. **All this with an upfront, all- inclusive, long-term cost proposal.**

Mosaic One will allow Superior Connect to quickly install and maintain Adtran's industry leading Combo PON including our 10G XGS-PON solution using our revolutionary SDX family. The disaggregated SDX family solution gives Superior Connect unlimited growth potential, unparalleled platform performance, and cost per subscriber that no other vendor can meet. By choosing the SDX solution with the capabilities of our MOSAIC suite, backed by the stability and customer service of Adtran, Superior Connect can be assured of optimum design flexibility and long-term investment protection, not only today, but for the years to follow as your deployment grows and prospers. Please see the Solution Overview for detailed information on Mosaic One, Adtran's SDX solution, CPE, and SDGs.

**Disaggregated OLTs** – With the ADTRAN 6000 OLT system ADTRAN can provide the highest density Combo-PON OLT's available on the market today along with providing solutions for low density areas, all using the same architecture. We recommend our Combo OLTs, SDX 6330-48, SDX 6320-16, and SDX 6324-4 providing GPON, XGS-PON and Combo-PON capabilities. A concise overview of our SDX 6000 OLTs can be found in the supporting document "ADTRAN SDX 6000 OLT Series – Datasheet.pdf".

**GPON/XGS-PON ONTs** – ADTRAN offers a full line of indoor and outdoor ONT devices, ranging from simple media converter ONTs to SMB ONTs for both GPON and XGS-PON networks. These ONTs provide options for 1G, 2.5G, and 10G LAN ports as well as various voice port options, battery backup options, and installation options. For more details, please refer to the Solution Description and the supporting documentation.

**Residential Gateways** - Adtran Residential Gateways are fully integrated service delivery platforms that optimize exceptional subscriber experience while reducing complexity in the home network. Adtran SDGs offer next-generation Wi-Fi 6, 6e, and 7 technology providing consistent, multi-gigabit performance combined with low latency and complete integration with Mosaic One, redefining what it means to be provide industry leading managed WIFI..

Adtran's RFP team has carefully reviewed the Superior Connect RFP. Adtran views all customers as partners and will always do what is right to make Superior Connect's FTTP offerings to the community successful. We feel confident that our solution, combined with a stable and thriving company established in 1985 is the right solution which will provide the lowest overall cost of ownership, highest reliability, and most complete solution available. Our team at Adtran looks forward to providing you with unparalleled support and unmatched customer service for many years to come.

**REQUEST FOR INFORMATION**  
**CONNECTSUPERIOR FIBER NETWORK EQUIPMENT AND SERVICES**  
**City of Superior, Wisconsin**

August 2023  
23-39-IT

## **Table of Contents**

- 1. INTRODUCTION**
- 2. ADMINISTRATIVE INFORMATION**
- 3. FORM AND CONTENT OF SUBMISSIONS**
- 4. SOLUTION SPECIFICATIONS AND SCOPE OF WORK**

SECTION 1	INTRODUCTION
-----------	--------------

### 1.1 Purpose

The City of Superior, Wisconsin, is seeking information from qualified value-added resellers (**VARs**) to provide network hardware, software, and installation services to implement a new **fiber to the premise** network. The **City** has begun implementation of its Broadband Business Plan for **ConnectSuperior**, which provides for construction of a carrier-class fiber network passing approximately 15,000 commercial and residential premises. The **City** is seeking a turnkey go-live ready system including all required hardware, software, installation materials, and professional services to implement the **ConnectSuperior** network described in this **RFI**. The **City's** goal is to receive information from VARs on the best open-access, multi-provider broadband solutions that exist in the market today.

ConnectSuperior will be built as an open-access, multi-provider network that is owned and operated by the City, while retail internet (and other) services are supplied by ISPs. The City will own the physical fiber infrastructure, including backbone, distribution and drops, as well as all equipment to support connectivity to ISPs. The City will provide only wholesale access services to ISPs on the network who will in turn retail their services to customers that sign up for service on the ConnectSuperior network.

The City is soliciting vendor solutions and pricing for the network hardware, software and professional services for installation. The City contemplates either passive optical or active ethernet access platforms to provide the wholesale services. VARs should provide the best solutions available to achieve the City's goals.

The **City** desires to establish, where possible, a direct relationship with all equipment and software manufacturers in the **Proposed Solution**. Therefore, any components in the **Proposed Solution** that are available for direct purchase by the **City** from the manufacturer must be quoted to allow for direct purchase. All manufacturer lead times for equipment must be included in the **Proposed Solution**.

The **City** wishes to contract with a **Seller** able to provide the turn-key go-live ready system specified in this **RFI**. Scope of work service requirements are more particularly identified in Section 4 of this RFI. Specifications and compatibility requirements are more particularly identified in Section 5.4 of this RFI.

Correction shown in red above was communicated in Addendum #1, September 13, 2023.

Adtran Response: Read and Understood.

Lead Times: As of 9/27/2023, lead times for major components of the proposed solution(s) range from 2 days, to 25 weeks. Lead times are fluid, and can change rapidly. In any successful relationship, communication is the key building block. Adtran's experienced Sales Team works with our customers to build a forecast to meet their growth expectations. With continued communication, and rolling forecasts, Adtran can meet the needs of your deployment plan.

## 1.2 Overview of the RFI Process

This **RFI** is designed to provide **Sellers** with the information necessary to develop a **Proposed Solution**. The **RFI** process is for the **City's** benefit and is intended to provide the **City** with competitive information to assist in a future procurement for equipment and services. It is not intended to be comprehensive. Each **Seller** is solely responsible for determining all factors affecting the design, configuration, and implementation of a comprehensive Submission that will accomplish the technical and business goals described by this **RFI**.

[Adtran Response: Read and Understood.](#)

## 1.3 RFI Schedule

The **City** will make every effort to adhere to the following schedule below; however, this schedule is subject to change. **Sellers** will be notified of significant schedule changes:

Action	Responsible Party	Target Date
Issuance of RFI	City	9/1/2023
Submission of Questions	Sellers	9/19/2023
Submission of Information	Sellers	10/3/2023

[Adtran Response: Read and Understood.](#)

## 1.4 Submission

The **Seller** shall submit a digital copy of their completed information to the City no later than 5:00 p.m. CT on the designated due date to darwinj@ci.superior.wi.us. Information received after the deadline for submission of Submissions as stated herein shall not be considered and shall be returned to the late proposer unopened.

[Adtran Response: Read and Understood.](#)



<b>SECTION 2      ADMINISTRATIVE INFORMATION</b>
--

**2.1 Questions, Requests for Clarification, and Suggested Changes**

Sellers are invited to submit written questions and requests for clarifications regarding the **RFI**. Sellers may also submit suggestions for changes to the specifications of this **RFI**. The questions, requests for clarifications, or suggestions must be in writing and received by Jane Darwin, Contract Analyst, via email at [darwinj@ci.superior.wi.us](mailto:darwinj@ci.superior.wi.us) on or before the date and time listed within the **RFI**. Oral questions will not be permitted. If the questions, requests for clarifications, or suggestions pertain to a specific section of the **RFI**, **Seller** shall reference the page and section number(s). The **City** will send written responses to questions, requests for clarifications, or suggestions received from **Sellers** before the date listed within the **RFI**. The **City's** written responses will become an addendum to the **RFI** and be provided to all potential **Sellers**.

The **City** assumes no responsibility for oral representations made by its officers or employees unless such representations are confirmed in writing and incorporated into the **RFI** through an addendum.

[Adtran Response: Read and Understood.](#)

**2.2 Costs of Preparing the Submission**

The costs of preparation and delivery of the Submission are solely the responsibility of the **Seller**.  
[Adtran Response: Read and Understood.](#)

**2.3 No Commitment to Contract**

This RFI is purely for informational purposes and the City is not obligated to consider or select any **Seller** in this or future procurements.  
[Adtran Response: Read and Understood.](#)

**2.4 Reference Checks**

The **City** reserves the right to contact any reference to assist in the evaluation of the Submission, to verify information contained in the Submission and to discuss the **Seller's** qualifications and the qualifications of any subcontractor identified in the Submission.  
[Adtran Response: Read and Understood.](#)

**2.5 Information from Other Sources**

The **City** reserves the right to obtain and consider information from other sources concerning a **Seller**, such as the **Seller's** capability and performance under other contracts, the qualifications of any subcontractor identified in the Submission, the **Seller's** financial stability, past or pending litigation, and other publicly available information.  
[Adtran Response: Read and Understood.](#)

<b>SECTION 3      FORM AND CONTENT OF SUBMISSIONS</b>
---

### 3.1 Instructions

These instructions prescribe the format and content of the Submission. They are designed to facilitate a uniform review process. Failure to adhere to the Submission format may result in the rejection of the Submission.

[Adtran Response: Read and Understood.](#)

### 3.2 Proposed Solution

The Seller shall submit an electronic copy of their **Proposed Solution** as a pdf, including:

- an executive summary of the **Proposed Solution**
- a diagram of the **Proposed Solution** showing the components, connectivity, and link speeds
- proposed rack elevations showing equipment power connections and breaker requirements
- A detailed bill of materials and cost estimates for the **Proposed Solution** including all hardware, software, professional services and ongoing licensing agreements
- a description of the **Proposed Solution** including data sheets, diagrams, and training catalogs
- references and contact information

A digital copy of the Submission shall be included with the submission in the most appropriate format of each item including MS Word, MS Excel, MS Visio, and/or Adobe Acrobat formats. All Exhibits required in the submission shall be completed and submitted in the format they were provided in the RFI. Sellers are required to submit electronic copies via email to darwinj@ci.superior.wi.us.

[Adtran Response: Read and Understood.](#)

### 3.3 References and Contact Information

The **City** requires sufficient corporate, financial, and reference information to adequately assess the qualifications of the **Seller** to sell, install, and support the **Proposed Solution**. The reference information will be used by the **City** to differentiate between **Sellers** with similar **Proposed Solutions**, and shall be provided in a separate document including the following information:

#### Corporate Information

The **Seller** shall provide an overview of their corporate structure. The overview should address the following specific items:

- Name, address, and contact information of the Company and representative
- Company History and Formation
- Ownership (Public or Privately Held)
- Number of Employees
- Organizational chart of the management and implementation teams for a proposed project

Implementation Experience

**ConnectSuperior** will operate in a competitive marketplace as an open-access network, therefore the **Seller's** experience implementing and supporting **open-access** networks will be crucial to the successful launch and ongoing operation of **ConnectSuperior**. To this end, the **Seller** shall provide a brief summary of their experience implementing and supporting carrier-class open-access networks. The summary should address the following specific experience:

- Implementations of municipal and/or commercial **open-access** networks
- Implementations of similar network architectures
- List of certifications relative to the **Proposed Solution** held by the implementation team
- List of partner certifications relative to the **Proposed Solution** held by the **Seller**

**Sellers** with specialization in the proposed equipment manufacturers' service provider architecture are preferred. Copies of formal manufacturer-conferred certifications including the certification name, description, requirements, and date of award/renewal should be provided in the **Seller's** response.

The **Seller** shall submit a list of three (3) **open-access** references who have deployed similar architectures within the last five (5) years. The reference information shall include the company name with dates of implementation along with the name, address, and phone number of the individual(s) that may be contacted at the company. **Seller** shall omit all homogenous enterprise IT deployments (i.e., private corporate-centric networks) from their response and references.

Adtran Response: [Compliant. Please reference the document "References and Contact Information.pdf" included with our response.](#)

**SECTION 4 SOLUTION SPECIFICATIONS AND SCOPE OF WORK**

The **Seller** shall provide the **Proposed Solution** (hardware) and services to the **City** in accordance with the requirements as provided in this Scope of Work (SoW). The **Proposed Solution** must include professional services to fully commission the network.

[Adtran Response: Read and Understood.](#)

**4.2 Solution Specifications**

The **ConnectSuperior** network will pass up to 15,000 premises with either a XGS-PON centrally split distribution system or 10 Gigabit Active Ethernet system connecting two access points of presence (POP) to a central data center for access to ISPs. The City’s intent is to evaluate both PON-based and Active Ethernet based distribution systems to assess overall functionality and cost. Seller should provide their best solution to meet the City’s needs.

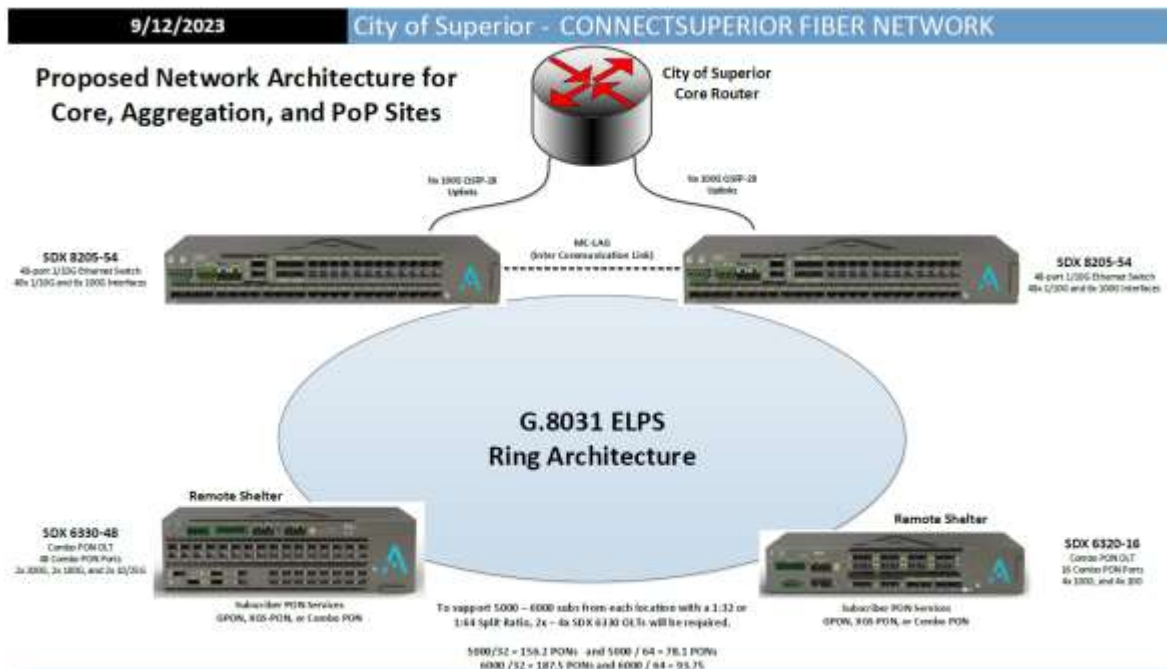

Adtran Response: Adtran proposes a disaggregated solution with two SDX 8205-54s. They will have a multi-chassis lag (MCL-AG) in the core along with 100G QSFP28 uplinks to the City of Superior core router. Adtran proposes a G.8031 ELPS ring architecture topology that connects the City of Superior’s core site with 100G QSFP28 10/40/80 km optics to the remote shelters that will house the PON OLT’s of the SDX 6330-48 and SDX 6320-16.

The SDX series of products design follows the disaggregated OLT system (OLT "blade" pizza boxes or remote OLTs + aggregation switch). The capacity size is limited only by the port count of the aggregation switch. Individual OLT blades or remote OLTs have a fixed number of ports, and the "backplane" speed is determined by the number of links between the OLT and aggregation switch. All SDX OLT platforms have sufficient upstream links to provide fully redundant non-blocking capacity.

The physical outside plant (**OSP**) architecture consists of multi-count single mode fiber rings connecting the data center, its collocated access POP, and remote access POPs to optical distribution networks (ODN) serving subscriber premises. POPs will be prefabricated shelters contain a -48v DC power system, 7' x 19" equipment racks, HVAC, cable ladder, and fiber distribution panels (FDPs) with SC/APC connector profiles.

Adtran Response: Adtran proposes a G.8031 ELPS ring architecture topology that connects the City of Superior's core with 100G QSFP28 10/40/80 km optics to the remote shelters that will house the PON OLT's of the SDX 6330 and SDX 6320. These SDX solutions can be deployed in a central office or remote environments along with fitting in a 19in rack mount. All proposed SDX solutions support dual feed -48VDC power.

## SDX 6000 Series OLTs

**Interfaces:** ITU-T Compliant for GPON and XGS-PON  
 Class B+, C+, C++, and D SFP Support (GPON)  
 Class N1, N2, D1, and D2 SFP+ Support (XGS-PON and Combo)  
 Forward Error Correction (FEC)

**Network Management:** NETCONF/YANG; CLI; Telnet/SSH;  
 IPv4/IPv6 In-Band / Out-of-Band Management

**Uplink Connectivity:** LAG with LACP Support, LLDP-Enabled;  
 Ethernet Linear Protection Switching (ELPS)

**Traffic Management:** HQoS Architecture w/ Flexible Multitier Scheduling  
 Rate Shapers Per Scheduled Node; Dynamic Bandwidth Allocation

**Security:** TACACS+ and RADIUS (Authentication, Authorization)  
 Subscriber Access Lists (ACL); AES Encryption; DoS Protection

**Subscriber Service Delivery:** G.988 VEIP Support For Residential Gateways;  
 Triple-Play – Voice, Video, and Data; IGMP Snooping and Proxy; Proxy ARP;  
 DHCP Relay For IPv4 and IPv6; DHCP Option 82 Support;  
 PPPoE Intermediate Agent



- **Core and Aggregation**

- Core electronics capable of supporting up to 15,000 residential and commercial customers. ConnectSuperior will maintain 2-3 POPs with 5,000 - 6,000 subscribers per POP.

Adtran Response: The proposed SDX 6000 series OLT solutions can support 5000 – 6000 subs from each location with a 1:32 or 1:64 Split Ratio. 2x – 4x SDX 6330 OLTs will be required to support up to 6000 subs, depending on PON Split Ratio used.

- 10 and 100 gigabit access facing interfaces

Adtran Response: The proposed SDX 8200 series and SDX 8120-14 aggregation solutions provide 1G and 10G services for subscriber termination. These 1G and 10G services may be terminated with the Adtran FSP-150 GE-104 (1G) and Adtran FSP-150 XG-108 devices.

Additionally, the SDX 8205-54 supports up to 6x 100G QSFP28 interfaces.

Please reference the City of Superior Network Concepts file and Supporting Documentation for more detailed information.

- 100 gigabit cross-connect interfaces between core devices

Adtran Response: The proposed SDX architecture provides two SDX 8205-54 aggregation devices at the Core site supporting MC-LAG between the devices. The Inter Communication Link (ICL) connection is supported by a 100G QSFP28 DAC Cable.

- 10 and 100 gigabit service provider facing interfaces (for connection to retail ISPs)

Adtran Response: The proposed SDX 8200 series and SDX 8120-14 aggregation solutions provide 1G and 10G services for subscriber termination. Additionally, the SDX 8205-54 supports up to 6x 100G QSFP28 interfaces.

- Support for SR-MPLS, EVPN and VRF

Adtran Response: This is a functionality of the City of Superior Core Router.

- Support for LAG and MC-LAG

Adtran Response: Compliant. Each of the proposed SDX 8000 series Aggregation and SDX 6000 series PON OLTs offers multiple 10G SFP+ and 100G QSFP28 interfaces to support the uplink LAG and MC-LAG configurations.

- SDX 6320-16
  - 4x100GE QSFP28 and 4x10GE SFP+ Uplinks
  - 16x Combo PON Ports
- SDX 6330-48
  - 2x200GE QSFP-DD, 2x100GE QSFP28, 2x SFP28 (SFP+) Uplinks
  - 48x Combo PON Ports
- SDX 8205-54
  - 6x100GbE QSFP28 48x10GbE SFP+

- Full QoS and traffic management solution

Adtran Response: The QoS traffic management network is applied after the downstream customer traffic has been classified and appropriately manipulated by the OLT, but before the traffic reaches the PON.

ADTRAN provides shapers per queue and per scheduling element to shape traffic from these queues. Policers only mark or drop packets, and do not change the rate of packets. Policer CIR and EIR rates, as well as burst sizes will be configurable.

Each service can be assigned a set of 4 queues, which could be expanded to 8 queues in future. Each set of queues is scheduled with strict priority. This can be modified to WFQ in future. Service queue sets are connected to parent schedulers that can be either SP or WFQ, up to 5 levels to the PON.

Additionally, the SDX 6000 series PON OLTs support Hierarchical Quality of Service (HQoS).

- Hierarchical Quality of Service (HQoS) is a tiered quality of service technology that classifies, and schedules traffic based on service requirements.
- The OLT supports a multi-tier network of schedulers. These tiers are listed as “Levels”.
- QoS provisioning is used to reduce packet delay and ensure reliability for each data packet on the network.
- Creating schedulers involves configuring CoS queues for service streams, so that the service streams can be manipulated by the QoS traffic management network.
- The QoS traffic management network is applied after the downstream customer traffic has been classified and appropriately manipulated by the OLT, but before the traffic reaches the PON.

- Full power and CPU redundancy

Adtran Response: The SDX series of products design follows the disaggregated OLT system (OLT "blade" pizza boxes or remote OLTs + aggregation switch). The capacity size is limited only by the port count of the aggregation switch. Individual OLT blades or remote OLTs have a fixed number of ports, and the "backplane" speed is determined by the number of links between the OLT and aggregation switch. All SDX OLT platforms have sufficient upstream links to provide fully redundant non-blocking capacity.

The SDX OLT series provides redundant Power Supplies, redundant Fans, and can be deployed in a Spine / Leaf architecture to offer a redundant mesh failover of the uplinks to the Core.

- Support for syslog, SNMP, trap and performance management in OSS software

Adtran Response: Syslog reporting from the management system and SDX OLT are supported by the solution. The management system details the specific details and configuration for syslog reporting by the devices and applies the provisioning to those devices. The devices send syslog data directly to the supporting syslog server. It does not go through an intermediary collection point.

SNMP is used for Trap forwarding only. Integration with an event processing application is

possible via Kafka or SNMP trap forwarder. Mosaic Cloud Platform REST API supports OSS integration. The Adtran solution supports a full Netconf/YANG NBI.

Real-time monitoring of the Node can be provided by the Adtran Telemetry application STaT App, which can provide Kafka topics that can be streamed to a Kafka broker for real-time streaming of data.

The Mosaic Cloud Platform allows users to view performance statistics and counters in order to troubleshoot line or service issues. These details are available for viewing on the GUI or via API. Adtran OLT series supports a wide range of statistics and performance monitoring data for PON, ONU, and ONU UNIs to ensure troubleshooting and statistics collection is available at all points within the system. Statistics range from Ethernet Bytes/Frames RX/TX, Multicast Bytes/Frames RX/TX, Multicast Utilization Average, OMCI Packets RX/TX, Packet Fragment Errors RX/TX, PON Utilization RX/TX, PON Peak Utilization, Dropped Packets RX/TX, Buffer Overflow RX, TX, and BIP Errors RX/TX and others.

- Support for out-of-band management and monitoring

Adtran Response: Mosaic Cloud Platform (MCP) has been architected to meet the needs of agility, on-demand, automated and flexible control for next generation networks from the cloud edge to the subscriber edge. The 'cloud edge' refers to central offices, both legacy and modern, rearchitected as data centers. It delivers carrier grade orchestration, control, and automation functionality through a set of modular software functions, built using a modern microservices architecture. It complements open source SDN controllers to provide orchestration, control and management features optimized for the access domain. It enables carriers to create and manage network objects, devices, interfaces, and services end-to-end.

Mosaic CP is built to tackle functions ranging from orchestration of disaggregated fiber access systems, OSS adapters, traditional fault, configuration, accounting, performance, and security (FCAPS) functions or advanced data mining and analytics. Mosaic CP is designed to meet the needs of today's networks while providing a foundation for the next-generation networks of tomorrow to enable an on-demand, agile service delivery framework.

- 24x7x365 next-business day hardware and software maintenance on critical components

Adtran Response: Adtran includes software maintenance, 24x7x365 SLA based access to Technical Support, and repair and return for hardware as part of Mosaic One as quoted in this response. In addition, Adtran offers next business day replacement (NBD) options. NBD is applicable to all serialized hardware other than ONTs, Residential Gateways, and PON Optics as these are typically spared by the service provider. NBD is priced at \$4200 for year 1 and at 3.5% of price of the installed base (IB) each year beginning in year 2. The installed base is calculated based on the cumulative spend on serialized hardware and embedded software other than ONTs, Residential Gateways, and PON Optics at the beginning of each year of the contract period beginning at year 2. NBD is also available on ONTs, Residential Gateways, and PON Optics. Please contact Adtran for a quote.

The standard warranty period starts at ship date from Adtran.



The software carries a standard 90-day warranty; however, as long as a valid and active Mosaic One contract that includes Mosaic One Enhanced Software Care is in effect, software maintenance is included until 3 years beyond the End-of-Support date which will be published at least 2 years prior to the end of support date as part of End-of-Life process. Customers may sign up at [adtran.com](http://adtran.com) for End-of-Life notifications.

Standard hardware warranty periods for the proposed equipment are noted in the BoM for this response. There is also a notation for Maximum Hardware Repair, which is the additional time that hardware repair can be purchased through a Mosaic One Enhanced Hardware Care, plus the standard warranty days. If the device shows 365 days standard warranty, and the Max Days Hardware Repair is 770 days, the time that can be purchased through a Mosaic One Enhanced Hardware Care is 365 days.

The Adtran Standard Warranty document has been included in the Supporting Documentation of this response.

- **Access**

- Access electronics capable of supporting up to 15,000 residential and commercial customers. ConnectSuperior will maintain 2 POPs with 6,000 subscribers per POP.

Adtran Response: Adtran proposes a disaggregated solution with two SDX 8205-54s. They will have a multi-chassis lag (MCL-LAG) in the core along with 100G QSFP28 uplinks to the City of Superior core router. Adtran proposes a G.8031 ELPS ring architecture topology that connects the City of Superior's core site with 100G QSFP28 10/40/80 km optics to the remote shelters that will house the PON OLT's of the SDX 6330-48 and SDX 6320-16.

The SDX series of products design follows the disaggregated OLT system (OLT "blade" pizza boxes or remote OLTs + aggregation switch). The capacity size is limited only by the port count of the aggregation switch. Individual OLT blades or remote OLTs have a fixed number of ports, and the "backplane" speed is determined by the number of links between the OLT and aggregation switch. All SDX OLT platforms have sufficient upstream links to provide fully redundant non-blocking capacity.

The proposed SDX 6000 series OLT solutions can support 5000 – 6000 subs from each location with a 1:32 or 1:64 Split Ratio. 2x – 4x SDX 6330 OLTs will be required to support up to 6000 subs, depending on PON Split Ratio used.

- Sub-gigabit, 1 gigabit and 10 gigabit subscriber services, scalable to 100 gigabit

Adtran Response: The proposed SDX 8200 series and SDX 8120-14 aggregation solutions provide 1G and 10G services for subscriber termination. These 1G and 10G services may be terminated with the Adtran FSP-150 GE-104 (1G) and Adtran FSP-150 XG-108 devices.

Additionally, the SDX 8205-54 supports up to 6x 100G QSFP28 interfaces.

Please reference the City of Superior Network Concepts file and Supporting Documentation for more detailed information.

- 10/100 gigabit interconnection with ISPs

Adtran Response: The proposed SDX 8200 series and SDX 8120-14 aggregation solutions provide 1G and 10G services for subscriber termination. Additionally, the SDX 8205-54 supports up to 6x 100G QSFP28 interfaces.

- XGS-PON or Active Ethernet access technology for subscriber-facing services

Adtran Response: The SDX 6000 series OLTs support GPON, XGS-PON, and COMBO-PON services for subscriber termination.

SDX 6320-16 supports up to 16 PON interfaces.  
SDX 6330-48 supports up to 48 PON interfaces.

GPON (B+, C+, C++, D)  
XGS-PON (N1, N2)  
COMBO-PON (D1, D2)

### THE BEST OF BOTH WORLDS Combo PON explained

- Deliver symmetric multi-Gigabit services for residential, business simultaneously
- Launch both GPON and/or XGS-PON simultaneously from a single PON port
- Simplifies migration from legacy GPON to higher capacity XGS-PON

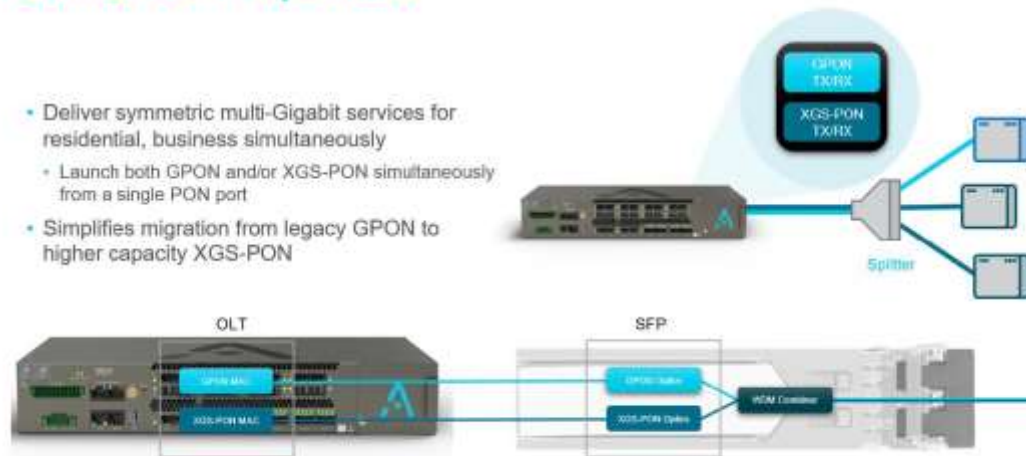

- Active Ethernet overlay to support dedicated customers, including community anchor institutions and large enterprises

Adtran Response: For dedicated customers, Adtran would propose delivering 1G and 10G services. The SDX 8200 series and SDX 8120-14 aggregation solutions provide 1G and 10G services for subscriber termination. These 1G and 10G services may be

terminated with the Adtran FSP-150 GE-104 (1G) and Adtran FSP-150 XG-108 devices.

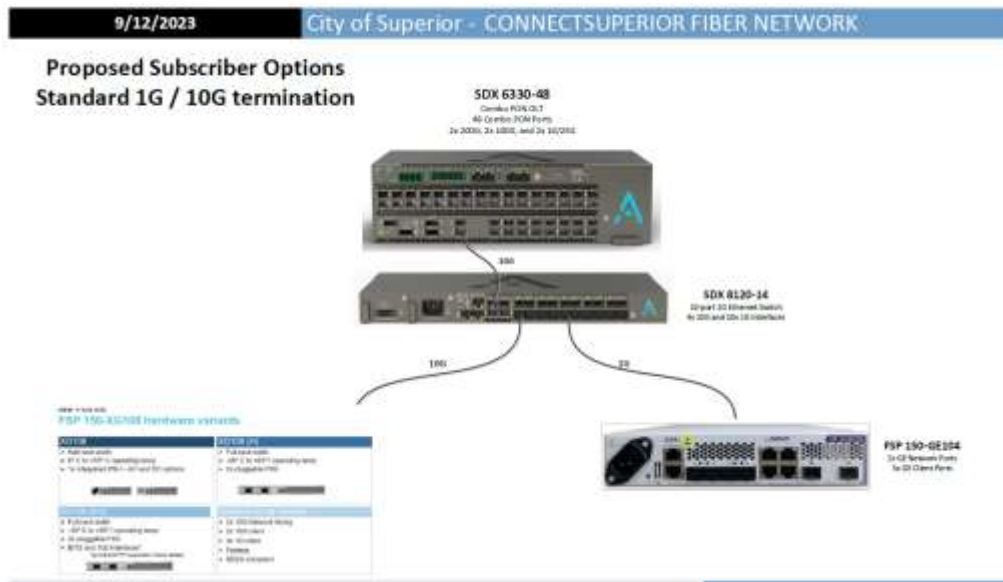

- Layer 2 segmentation technology provide separate VLANs/VPNs for each ISP and its customers on the open-access network

Adtran Response: The SDX 6000 series OLT solutions support a wide range of VLAN transport options to ensure the ability to deliver business and residential services based on the planned (and current) network architecture. Additional VLAN manipulation and transport capabilities exist with the SDX Aggregation devices that may be deployed in conjunction with the SDX OLTs.

The SDX 6000 series OLTs support the following VLAN Models for deployment:

- N:1 Residential Data Service VLAN
- N:1 Service VLAN

## N:1 Residential Data Service VLAN

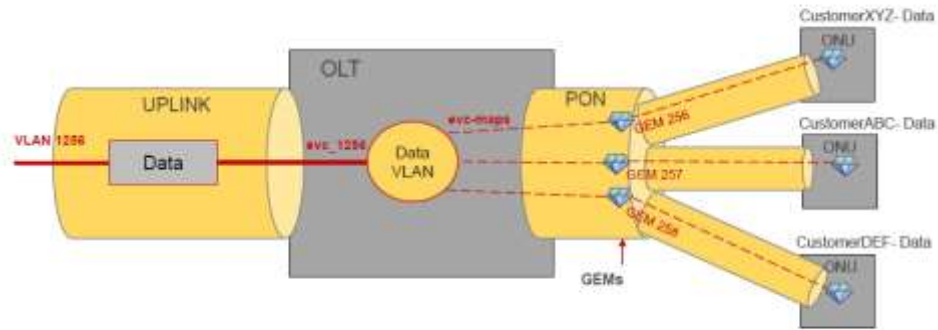

## N:1 Service VLAN

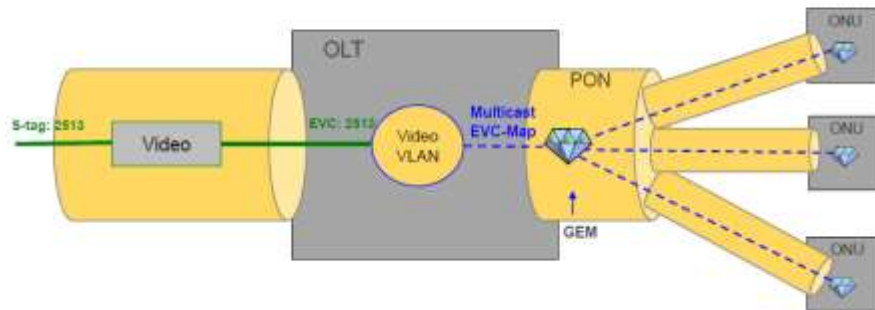

## N:1 Service VLAN

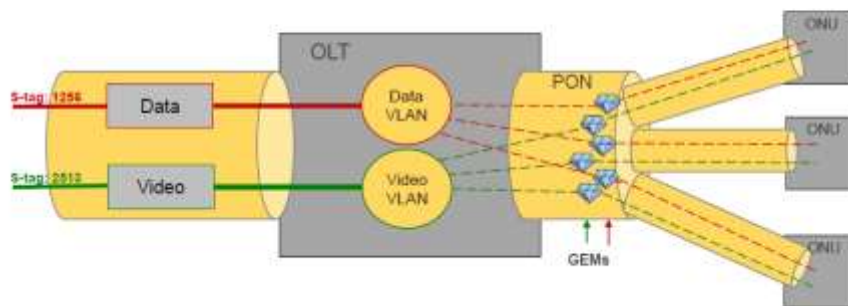

- Full QoS and traffic management solution

Adtran Response: The QoS traffic management network is applied after the downstream customer traffic has been classified and appropriately manipulated by the OLT, but before the traffic reaches the PON.

ADTRAN provides shapers per queue and per scheduling element to shape traffic from these ConnectSuperior City of Superior Fiber Network Equipment and Services RFI

queues. Policers only mark or drop packets, and do not change the rate of packets. Policer CIR and EIR rates, as well as burst sizes will be configurable.

Each service can be assigned a set of 4 queues, which could be expanded to 8 queues in future. Each set of queues is scheduled with strict priority. This can be modified to WFQ in future. Service queue sets are connected to parent schedulers that can be either SP or WFQ, up to 5 levels to the PON.

Additionally, the SDX 6000 series PON OLTs support Hierarchical Quality of Service (HQoS).

- Hierarchical Quality of Service (HQoS) is a tiered quality of service technology that classifies, and schedules traffic based on service requirements.
- The OLT supports a multi-tier network of schedulers. These tiers are listed as “Levels”.
- QoS provisioning is used to reduce packet delay and ensure reliability for each data packet on the network.
- Creating schedulers involves configuring CoS queues for service streams, so that the service streams can be manipulated by the QoS traffic management network.
- The QoS traffic management network is applied after the downstream customer traffic has been classified and appropriately manipulated by the OLT, but before the traffic reaches the PON.

- Full power and CPU redundancy

Adtran Response: The SDX series of products design follows the disaggregated OLT system (OLT "blade" pizza boxes or remote OLTs + aggregation switch). The capacity size is limited only by the port count of the aggregation switch. Individual OLT blades or remote OLTs have a fixed number of ports, and the "backplane" speed is determined by the number of links between the OLT and aggregation switch. All SDX OLT platforms have sufficient upstream links to provide fully redundant non-blocking capacity.

The SDX OLT series provides redundant Power Supplies, redundant Fans, and can be deployed in a Spine / Leaf architecture to offer a redundant mesh failover of the uplinks to the Core.

- Support for syslog, SNMP, trap and performance management in OSS software

Adtran Response: Syslog reporting from the management system and SDX OLT are supported by the solution. The management system details the specific details and configuration for syslog reporting by the devices and applies the provisioning to those devices. The devices send syslog data directly to the supporting syslog server. It does not go through an intermediary collection point.

SNMP is used for Trap forwarding only. Integration with an event processing application is

possible via Kafka or SNMP trap forwarder. Mosaic Cloud Platform REST API supports OSS integration. The Adtran solution supports a full Netconf/YANG NBI.

Real-time monitoring of the Node can be provided by the Adtran Telemetry application STaT App, which can provide Kafka topics that can be streamed to a Kafka broker for real-time streaming of data.

The Mosaic Cloud Platform allows users to view performance statistics and counters in order to troubleshoot line or service issues. These details are available for viewing on the GUI or via API. Adtran OLT series supports a wide range of statistics and performance monitoring data for PON, ONU, and ONU UNIs to ensure troubleshooting and statistics collection is available at all points within the system. Statistics range from Ethernet Bytes/Frames RX/TX, Multicast Bytes/Frames RX/TX, Multicast Utilization Average, OMCI Packets RX/TX, Packet Fragment Errors RX/TX, PON Utilization RX/TX, PON Peak Utilization, Dropped Packets RX/TX, Buffer Overflow RX, TX, and BIP Errors RX/TX and others.

- Support for out-of-band management and monitoring

Adtran Response: Mosaic Cloud Platform (MCP) has been architected to meet the needs of agility, on-demand, automated and flexible control for next generation networks from the cloud edge to the subscriber edge. The 'cloud edge' refers to central offices, both legacy and modern, rearchitected as data centers. It delivers carrier grade orchestration, control, and automation functionality through a set of modular software functions, built using a modern microservices architecture. It complements open source SDN controllers to provide orchestration, control and management features optimized for the access domain. It enables carriers to create and manage network objects, devices, interfaces, and services end-to-end.

Mosaic CP is built to tackle functions ranging from orchestration of disaggregated fiber access systems, OSS adapters, traditional fault, configuration, accounting, performance, and security (FCAPS) functions or advanced data mining and analytics. Mosaic CP is designed to meet the needs of today's networks while providing a foundation for the next-generation networks of tomorrow to enable an on-demand, agile service delivery framework.

- 24x7x365 next-business day hardware maintenance on critical components

Adtran Response: Adtran includes software maintenance, 24x7x365 SLA based access to Technical Support, and repair and return for hardware as part of Mosaic One as quoted in this response. In addition, Adtran offers next business day replacement (NBD) options. NBD is applicable to all serialized hardware other than ONTs, Residential Gateways, and PON Optics as these are typically spared by the service provider. NBD is priced at \$4200 for year 1 and at 3.5% of price of the installed base (IB) each year beginning in year 2. The installed base is calculated based on the cumulative spend on serialized hardware and embedded software other than ONTs, Residential Gateways, and PON Optics at the beginning of each year of the contract period beginning at year 2. NBD is also available on ONTs, Residential Gateways, and PON Optics. Please contact Adtran for a quote.

The standard warranty period starts at ship date from Adtran.

The software carries a standard 90-day warranty; however, as long as a valid and active Mosaic One contract that includes Mosaic One Enhanced Software Care is in effect, software maintenance is included until 3 years beyond the End-of-Support date which will be published at least 2 years prior to the end of support date as part of End-of-Life process. Customers may sign up at [adtran.com](http://adtran.com) for End-of-Life notifications.

Standard hardware warranty periods for the proposed equipment are noted in the BoM for this response. There is also a notation for Maximum Hardware Repair, which is the additional time that hardware repair can be purchased through a Mosaic One Enhanced Hardware Care, plus the standard warranty days. If the device shows 365 days standard warranty, and the Max Days Hardware Repair is 770 days, the time that can be purchased through a Mosaic One Enhanced Hardware Care is 365 days.

Adtran Enhanced Network Care Plan (ENCP) will cover the new gear. Upon expiration of that plan, a renewal quote will be generated with pricing based on the Service Provider’s total number of devices, nodes, and subscribers at that time. For description of ENCP SLAs, please refer to the Mosaic One General Terms and Conditions document, included in the supporting documentation of our response.

The Adtran Standard Warranty document has been included in the Supporting Documentation of this response.

- **Subscriber ONT**

- XGS-PON or Active Ethernet per vendor’s solution

Adtran Response: The proposed SDX 630 series ONTs support XGS-PON services from the Core SDX 6000 series OLTs.

- Support for indoor and outdoor options

Adtran Response: Adtran supports indoor units in the SDX 630 series along with an outdoor solution being the SDX 632vh. Please reference the following table for options.

	630	631	631q	632v	631qv	632vh	634w
<b>Housing</b>	Indoor	Indoor	Indoor	Indoor	Indoor	Outdoor	Indoor
<b>VoIP</b>				1	1	1	2
<b>2.5G UNI</b>			1	1	1	1	3
<b>10G UNI</b>	1 SFP+	1		1		1	1

- 1GE LAN port

Adtran Response: Please reference the following table for options.

	630	631	631q	632v	631qv	632vh	634w
<b>Housing</b>	Indoor	Indoor	Indoor	Indoor	Indoor	Outdoor	Indoor
<b>VoIP</b>				1	1	1	2
<b>2.5G UNI</b>			1	1	1	1	3
<b>10G UNI</b>	1 SFP+	1		1		1	1

- 1 POTS line  
Adtran Response: Please reference the following table for options.

	630	631	631q	632v	631qv	632vh	634w
<b>Housing</b>	Indoor	Indoor	Indoor	Indoor	Indoor	Outdoor	Indoor
<b>VoIP</b>				1	1	1	2
<b>2.5G UNI</b>			1	1	1	1	3
<b>10G UNI</b>	1 SFP+	1		1		1	1

- Wireless gateway for all-in-one ONT+Gateway functionality

Adtran Response: With the proposed SDX 630 series ONTs and the SDG 800 / 8600 series Service Delivery Gateways, two options may be provided.

A single box solution deploying the SDX 630 XGS-PON SFP+ ONT inserted in the SDG 854-v6 or the SDG 8614 WiFi gateways may be used.

A two-box solution deploying a SDX 630 series ONT and ethernet feeding the SDX 800 / 8600 series WiFi gateway.



**SDG PORTFOLIO**  
**SDG 800 Series (Hardware)**



	Model	Wi-Fi	WAN	LAN	2.4GHz	5GHz <sup>1</sup>	5GHz <sup>2</sup>
Dual-band Wi-Fi 5	834-5	Wi-Fi 5	1 GbE	4 x GbE	4x4	4x4	-
	834-v6	Wi-Fi 6	1 GbE	4 x GbE 1 x Voice	2x2	2x2	-
Dual-band Wi-Fi 6	854-6	Wi-Fi 6	2.5GbE (SFP+ / Ethernet)	4 x GbE	4x4	4x4	-
	854-v6	Wi-Fi 6	2.5GbE (SFP+ / Ethernet)	4 x GbE 2 x Voice	4x4	4x4	-
Tri-band Wi-Fi 6	841-6	Wi-Fi 6	2.5GbE	2.5GbE or 1 x GbE	2x2	2x2	4x4

**BUILT FOR THE MULTIGIGABIT ERA**  
**SDG 86xx Series**

Multigigabit-ready (wireless and wired)

- Two Dual-band, 4-port RGs
- Two Tri-band, 2-port AP/RG, one with 6E

	Model	Wi-Fi Gen	WAN	LAN	2.4GHz	5GHz <sup>1</sup>	5GHz <sup>2</sup>	6GHz
6ax DB	8612	Wi-Fi 6	2.5GbE	2.5GbE + 3x GbE	4x4	4x4	-	-
	8614	Wi-Fi 6	SFP+ (2.5Gbps)	2.5GbE + 3x GbE	4x4	4x4	-	-
6ax TB	8622	Wi-Fi 6	2.5GbE	2.5GbE	4x4	4x4	4x4	-
6axE TB	8632	Wi-Fi 6E	2.5Gbe	2.5Gbe	4x4	4x4	-	4x4



- Out-of-band management and monitoring

Adtran Response: Mosaic Cloud Platform (MCP) has been architected to meet the needs of agility, on-demand, automated and flexible control for next generation networks from the cloud edge to the subscriber edge. The ‘cloud edge’ refers to central offices, both legacy and modern, rearchitected as data centers. It delivers carrier grade orchestration, control, and automation functionality through a set of modular software functions, built using a modern microservices architecture. It complements open source SDN controllers to provide

orchestration, control and management features optimized for the access domain. It enables carriers to create and manage network objects, devices, interfaces, and services end-to-end.

Mosaic CP is built to tackle functions ranging from orchestration of disaggregated fiber access systems, OSS adapters, traditional fault, configuration, accounting, performance, and security (FCAPS) functions or advanced data mining and analytics. Mosaic CP is designed to meet the needs of today's networks while providing a foundation for the next-generation networks of tomorrow to enable an on-demand, agile service delivery framework.

In the event the Adtran Service Delivery Gateways (SDGs) are used for RG and WiFi purpose in the Subscriber location, Mosaic One (M1) Suite of Tools is offered to assist with the management and monitoring of the network.

Mosaic One is a set of easy-to-use, intelligent SaaS features purpose-built for marketing, customer success, and operations teams at traditional broadband operators and alternate service providers. Mosaic One Promote, Operate, and Care SaaS tools empower the marketing, operations, and customer success teams.

- Mosaic One Promote: Empowers marketers to deliver intelligent broadband by enabling them to leverage subscribers' online user behavior and segment them as gamers, streamers, or surfers.
- Mosaic One Operate: Enables operations teams to monitor the access and subscribers' network for alarms and proactively correct them to minimize downtime.
- Mosaic One Care: End-to-end troubleshooting, so customer success teams can assess the access network, the subscribers' network, and even study and manage the far end CPE device within minutes.

- Support for syslog, SNMP, trap and performance management in OSS software

Adtran Response: Syslog reporting from the management system and SDX OLT are supported by the solution. The management system details the specific details and configuration for syslog reporting by the devices and applies the provisioning to those devices. The devices send syslog data directly to the supporting syslog server. It does not go through an intermediary collection point.

SNMP is used for Trap forwarding only. Integration with an event processing application is possible via Kafka or SNMP trap forwarder. Mosaic Cloud Platform REST API supports OSS integration. The Adtran solution supports a full Netconf/YANG NBI.

Real-time monitoring of the Node can be provided by the Adtran Telemetry application STaT App, which can provide Kafka topics that can be streamed to a Kafka broker for real-time streaming of data.

The Mosaic Cloud Platform allows users to view performance statistics and counters in order to troubleshoot line or service issues. These details are available for viewing on the GUI or via API. Adtran OLT series supports a wide range of statistics and performance monitoring data for PON, ONU, and ONU UNIs to ensure troubleshooting and statistics collection is available at

all points within the system. Statistics range from Ethernet Bytes/Frames RX/TX, Multicast Bytes/Frames RX/TX, Multicast Utilization Average, OMCI Packets RX/TX, Packet Fragment Errors RX/TX, PON Utilization RX/TX, PON Peak Utilization, Dropped Packets RX/TX, Buffer Overflow RX, TX, and BIP Errors RX/TX and others.

- Support for out-of-band management and monitoring

Adtran Response: Mosaic Cloud Platform (MCP) has been architected to meet the needs of agility, on-demand, automated and flexible control for next generation networks from the cloud edge to the subscriber edge. The ‘cloud edge’ refers to central offices, both legacy and modern, rearchitected as data centers. It delivers carrier grade orchestration, control, and automation functionality through a set of modular software functions, built using a modern microservices architecture. It complements open source SDN controllers to provide orchestration, control and management features optimized for the access domain. It enables carriers to create and manage network objects, devices, interfaces, and services end-to-end.

Mosaic CP is built to tackle functions ranging from orchestration of disaggregated fiber access systems, OSS adapters, traditional fault, configuration, accounting, performance, and security (FCAPS) functions or advanced data mining and analytics. Mosaic CP is designed to meet the needs of today’s networks while providing a foundation for the next-generation networks of tomorrow to enable an on-demand, agile service delivery framework.

- **Dedicated ONT**

- For large enterprise and community anchor organizations

Adtran Response: Adtran supports indoor units in the SDX 630 series along with an outdoor solution being the SDX 632vh. Please reference the following table for options.

	630	631	631q	632v	631qv	632vh	634w
<b>Housing</b>	Indoor	Indoor	Indoor	Indoor	Indoor	Outdoor	Indoor
<b>VoIP</b>				1	1	1	2
<b>2.5G UNI</b>			1	1	1	1	3
<b>10G UNI</b>	1 SFP+	1		1		1	1

Adtran offers Indoor and Outdoor MDU 485 shelf (Indoor) and 480 housing (outdoor) options to support higher port density if desired.

- 1, 10 and 100 Gigabit interfaces, both network and customer facing

Adtran Response: For dedicated customers, Adtran would propose delivering 1G and 10G services. The SDX 8200 series and SDX 8120-14 aggregation solutions provide 1G and 10G services for subscriber termination. These 1G and 10G services may be terminated with the Adtran FSP-150 GE-104 (1G) and Adtran FSP-150 XG-108 devices.

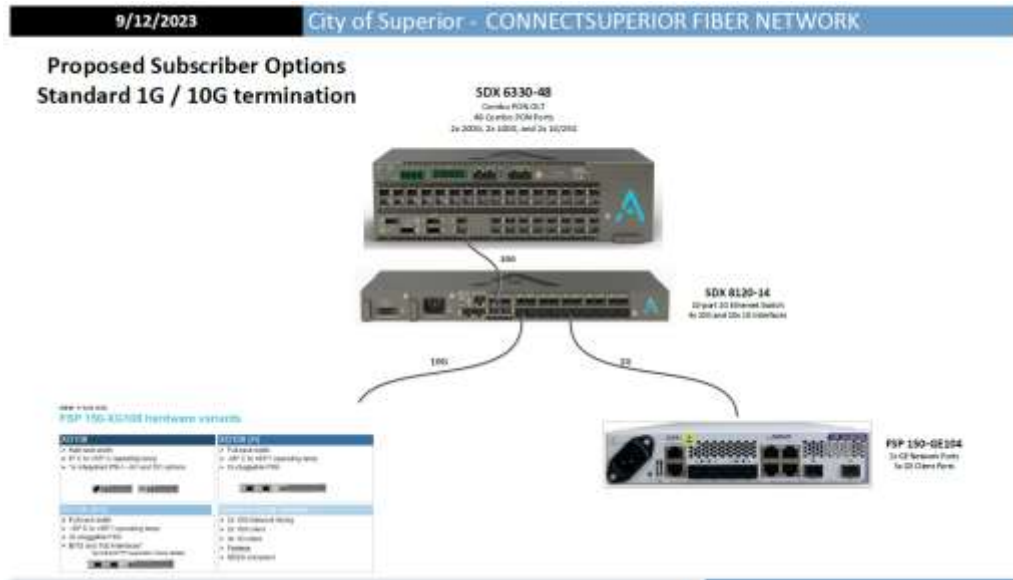

In the event, 100G services are needed, the planned 1H 2024 release of the SDX 8230-14 and SDX 8230-20 will provide 100G support.

- Support for syslog, SNMP, trap and performance management in OSS software

Adtran Response: See above.

- Support for out-of-band management and monitoring

Adtran Response: See above.

- 24x7x365 next-business day hardware and software maintenance on critical components

Adtran Response: Adtran includes software maintenance, 24x7x365 SLA based access to Technical Support, and repair and return for hardware as part of Mosaic One as quoted in this response. In addition, Adtran offers next business day replacement (NBD) options. NBD is applicable to all serialized hardware other than ONTs, Residential Gateways, and PON Optics as these are typically spared by the service provider. NBD is priced at \$4200 for year 1 and at 3.5% of price of the installed base (IB) each year beginning in year 2. The installed base is calculated based on the cumulative spend on serialized hardware and embedded software other than ONTs, Residential Gateways, and PON Optics at the beginning of each year of the contract period beginning at year 2. NBD is also available on ONTs, Residential Gateways, and PON Optics. Please contact Adtran for a quote.

The standard warranty period starts at ship date from Adtran.

The software carries a standard 90-day warranty; however, as long as a valid and active Mosaic One contract that includes Mosaic One Enhanced Software Care is in effect, software

maintenance is included until 3 years beyond the End-of-Support date which will be published at least 2 years prior to the end of support date as part of End-of-Life process. Customers may sign up at [adtran.com](http://adtran.com) for End-of-Life notifications.

Standard hardware warranty periods for the proposed equipment are noted in the BoM for this response. There is also a notation for Maximum Hardware Repair, which is the additional time that hardware repair can be purchased through a Mosaic One Enhanced Hardware Care, plus the standard warranty days. If the device shows 365 days standard warranty, and the Max Days Hardware Repair is 770 days, the time that can be purchased through a Mosaic One Enhanced Hardware Care is 365 days.

- **Element Management System**

- Support for syslog, SNMP, trap and performance management in OSS software

Adtran Response: Syslog reporting from the management system and SDX OLT are supported by the solution. The management system details the specific details and configuration for syslog reporting by the devices and applies the provisioning to those devices. The devices send syslog data directly to the supporting syslog server. It does not go through an intermediary collection point.

SNMP is used for Trap forwarding only. Integration with an event processing application is possible via Kafka or SNMP trap forwarder. Mosaic Cloud Platform REST API supports OSS integration. The Adtran solution supports a full Netconf/YANG NBI.

Real-time monitoring of the Node can be provided by the Adtran Telemetry application STaT App, which can provide Kafka topics that can be streamed to a Kafka broker for real-time streaming of data.

The Mosaic Cloud Platform allows users to view performance statistics and counters to troubleshoot line or service issues. These details are available for viewing on the GUI or via API. Adtran OLT series supports a wide range of statistics and performance monitoring data for PON, ONU, and ONU UNIs to ensure troubleshooting and statistics collection is available at all points within the system. Statistics range from Ethernet Bytes/Frames RX/TX, Multicast Bytes/Frames RX/TX, Multicast Utilization Average, OMCI Packets RX/TX, Packet Fragment Errors RX/TX, PON Utilization RX/TX, PON Peak Utilization, Dropped Packets RX/TX, Buffer Overflow RX, TX, and BIP Errors RX/TX and others.

- Full user interface and dashboards for alarm management, traffic management, capacity planning, inventory and reporting

Adtran Response: Mosaic Cloud Platform is designed based on microservices architecture. The platform is made up of several microservices, packaged in different docker containers. These service coordinate using an Active MQ based messaging bus. The presentation (GUI) is browser based. The programming interface (NBI) is RESTCONF based. The GUI uses the same NBI that is offered to OSS. The presentation and processing are distinct microservices.

Alarm configuration and suppression are supported at the local device level as well as through

the management system. A flexible arrangement is possible whereby the management system can establish a consistent approach for all devices as a part of network onboarding. Logs and events are automatically generated and captured as necessary. Alarms are generated upon appropriate fault condition scenario. Critical and Major alarms are typically service affecting. The SDX Aggs and OLTs support alarm pin contacts for Alarm I/O.

Fault diagnostics are supported by the SDX series of products ranging from internal exception reports, alarms, syslog reports, and inventory information.

Additionally, when deploying the SDG 800 / 8600 series WiFi Gateways, Mosaic One (M1) suite of tools may be utilized. Mosaic One Operate enables operations teams to monitor the access and subscribers' network for alarms and proactively correct them to minimize downtime.

The Mosaic Cloud Platform allows users to view performance statistics and counters to troubleshoot line or service issues. These details are available for viewing on the GUI or via API.

Real-time monitoring of the Node can be provided by the Adtran Telemetry application STaT App, which can provide Kafka topics that can be streamed to a Kafka broker for real-time streaming of data.

- Provisioning for all subscriber services, including residential single-family, multifamily, commercial and community anchor

Adtran Response: Adtran is proposing Mosaic Cloud Platform (MCP), acting as an access domain SDN controller and orchestrator, provides an evolution from vendor-specific element management systems using semi-automated provisioning of individual access technologies to support fully automated orchestration and SDN control of multi-vendor, multi-technology networks operating across multiple domains. Mosaic CP is built to tackle functions such as orchestration of disaggregated fiber access systems, OSS adapters, and traditional fault, configuration, accounting, performance, and security (FCAPS) functions.

**Product Features:**

- FCAPS/EMS features
- End-to-end multi-vendor, multi-technology service orchestration
- End-to-end service level APIs and abstraction to legacy and modern devices
- Integrates open source, access-optimized controllers
- Zero-touch commissioning of network devices
- Persistent configuration for offline service provisioning
- Reflow of service provisioning
- Bulk PM/telemetry collection and storage (including streaming telemetry)
- Closed-loop automation applications
- Real-time service assurance collection and monitoring
- OSS adapters to translate back to operator-specific OSS interfaces
- Configurable southbound and northbound plugins

**Product Specifications**

Mosaic Cloud Platform is packaged as an installer, providing flexible options across a wide range of installation environments. It supports deployments across data centers in an active – standby configuration

**Recommended Minimum Requirements\***

**Virtual Machine Specs**

- Base Memory: 16 GB
- Processor(s): 4 CPU cores
- Storage: 500 GB

**Operating System Specs**

- CentOS 7.x
- RedHat 7.x
- RedHat 8.x

For daily maintenance on the MCP Management System, MCP supports a wide range of flexible “Jobs”, to include Software Upgrade, Reboot, Reflow, Backup, Restore, etc...

“Jobs” are actions which can be configured to run on a given trigger:

- Date-Time
- On-Activate
- API-Triggered

A Backup Device Configuration Job stores the device running configuration in the Mosaic CP Kafka database. Similarly, a complete Restore Device Configuration Job can be executed, which restores the device running configuration for a device to a given backup instance.

Additionally, MCP supports Auto Provisioning capabilities to provide an easier PON network turnup for the Service Provider. Please reference the illustration below:

## Mosaic CP Auto Provisioning

Mosaic CP supports the **Auto building of objects**

- A complete configure and deploy of all OLT bundles, PON interfaces, ONUs, and UNIs can be achieved.
- A partial set of these objects can also be configured and deployed

**Object creation** is initiated by a **profile** that is in the **profile vector** of the preceding object.

- This profile will include a reference to the profile vector for the object being created

Auto Building of objects can be segmented in a variety of ways:

- PON only, PON to ONU, ONU to UNI, PON to UNI

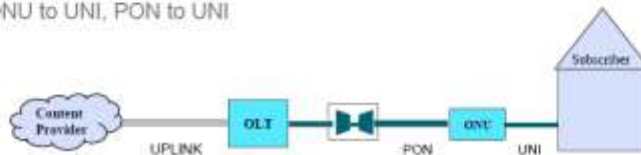

- Subscriber usage reporting to support bill generation

Adtran Response: MCP provides a consistent northbound service-oriented interface to existing OSS systems and a bridge to next-generation network automation platforms, regardless of vendor, platform, or technology. Mosaic CP is the network management system of today and next-generation network automation platform of tomorrow.

Mosaic Cloud Platform has a published API and is integrated into OSS/BSS systems.

- **Self-Provisioning Features**

- Subscriber self-provisioning system, allowing a customer to select their ISP, speed and ConnectSuperior City of Superior Fiber Network Equipment and Services RFI



package and switch ISPs, start and stop service

Adtran Response: The Adtran solution allows auto activation which will allow a user to come online. The authentication server, working together with the router can put an unauthenticated user to a walled garden where a user can be presented with service options. Once service is chosen, notification can be sent to the provisioning system which would push the proper provisioning to the network to match the service and service provider selected. Adtran can work with Superior Connect or can turn-key this customization. A scope of work and associated quote can be discussed once all the components of the network are identified.



### 4.3 Professional Services Scope of Work

#### 4.3.1 Pre-installation Planning (Onsite)

- Review readiness of sites for equipment installation and power
- Make arrangements for site access
- Evaluate rack elevations
- Evaluate power, distribution, and receptacle types
- Evaluate fiber distribution panel locations and connector profiles
- Identify required fiber strands/ports
- Develop a list of installation materials and procurement plan
  - Fiber and copper jumper cables
  - Equipment power wiring, fusing, and grounding components
  - Equipment mounting hardware
  - Determine sourcing for procurement
  - Assist **City** in creating BoM for procurement of installation materials

#### Adtran Response:

- The site survey shall capture details pertinent to engineering the implementation of an ADTRAN SDX shelf into an existing relay rack or cabinet. This site survey will capture all site-specific details required to design the site including space, power, heat, and cable management. These details will be captured on an ADTRAN site survey form and will be provided to the customer via final engineering documents for future use.
- Site Engineering ensures all installation requirements of a project are accounted for before the installation of an ADTRAN SDX shelf, the installer has all required documentation required to successfully complete install, and the customer has a detailed record of what was deployed into their network. During the Site Engineering phase of a project, ADTRAN will produce a detailed engineering design package to include the following:
  - Bill of materials, both ADTRAN and 3rd party, required to complete the installation.
  - Rack drawing of the existing rack and ADTRAN SDX shelf.
  - Network diagram showing the ADTRAN SDX uplink and distribution connections.
  - Detailed installation instructions and documentation.
  - Cable running list detailing all power and fiber runs required to deploy the shelf.

#### 4.3.2 High Level Configuration Design – (Remote)

- Conduct interactive design sessions with **City** and its service providers
- Define OTT video and VoIP integration requirements if any
- Define **City** subscriber services and QoS requirements
- Define requirements for open-access architecture and integration
- Define requirements for layer 2 services and BNG architecture
- Define subscriber service profiles for access network
- Define business network and OSS requirements
- Create high level design using inputs from interactive network design session
- Validate and finalize high level design with **City**

##### Adtran Response for a typical High Level Design:

- Topology view – This would be used to provide the high-level topology of the network including transport & access components.
- Chassis view – This would be used to capture either the transport or access chassis views to provide an overview of components in the chassis.
- The following items are to be included as a minimum for all HLDs:
  - Chassis level overview of equipment being proposed
  - All CPE and/or ancillary components being provided
  - Software representation (local or hosted)
  - Network Service dependencies (OSS/BSS, Monitoring, DHCP, etc)
  - Interface types and speeds between all equipment elements (Rings, LAGs, 10G,40G,100G)
  - Clear demarcation of network elements and responsibility (i.e. aggregation switch/router or 3rd party GW)
  - Network care plan, Any professional service line items
  - Services expectations (ex IPv4/IPv6, Data-Tagged/untagged, VoIP-SIP/MGCP, IPTV)

#### 4.3.3 Equipment Installation and Configuration Loads – (Onsite)

- Rack/Stack/Power equipment
- Install fiber jumpers and cabling as required by the low-level design
- Coordinate with ISPs for installation
- Develop low level configurations and documentation
- Install latest stable release software
- Create and load individual device configurations
- Validate and test low-level design and device configurations
- Install out-of-band management and telemetry systems

##### Adtran Response:

- SDX OLT Installation (existing cabinet or rack)

- Provide the specific tools, hardware, and software required to perform this service
- Move equipment to correct location within site, unpack and verify delivery against shipping list and dispose of all packaging
- Installation of active equipment to rack, slotting of SFPs
- Running, cleaning, and test all intra and inter rack optical cabling from SDX equipment to termination points
- Power up checks including verification of visual alarm statuses
- Complete all power, fiber and rack labeling in accordance with the customer specifications
- Test & Turn-up SDX-6000 series shelf
  - Test and turn up the (1) SDX-6000 series shelf into Customer’s network onboarding through MCP
  - Upgrade to latest software release if required
  - Build customer service profiles (Data, video, voice)
  - Build service vector profiles (speed profiles and auto builders)
  - Run Management profile script with information provided by customer
  - Management IP – Inband/Out of band
  - Management VLAN
  - Management Gateway
  - Management Subnet
  - Uplink Configuration 10G or 100G/200G/LAG
  - Set Clock parameter
  - Onboard SDX-6000 series shelf into MCP

#### 4.3.4 Acceptance Testing Plan (ATP) – (Onsite)

- Deploy local speed test server on business network VM
- Verify performance of network relative to the low-level design
- Simulate component and link failures to ensure proper operation of hardware and software redundancy mechanisms
- Verify operations of services failover and high availability functionality
- Perform end-to-end testing to validate network performance through gateways
- Verify performance of subscriber CPE and services

##### Adtran Response:

- Adtran is happy to help Superior deploy a local speed test server; however, we would like to have further discussions with Superior on the needs and requirements of a local speed test server.
- All testing will be completed per requirements. Any link fail overs pertaining to the Core device will require the customer’s engagement. Any hardware failures will be addressed as stated in the response for the Equipment Warranty Requirements.
- Adtran will test and verify operation on a minimum of 2 PON ports per SDX shelf to test backhaul connectivity from the ONT through the CORE

- Adtran Engineer will on-board the ONT's into MCP, create the test service in MCP and then perform the tests to ensure throughput and speeds.

#### 4.3.5 Training – (Onsite and/or Remote)

- Basic network training on:
  - Hardware and software configuration
  - high-level troubleshooting techniques
  - in-band and out-of-band management access
- Basic subscriber and service training on:
  - creation and modification of subscribers
  - creation and modification of service packages
  - management of subscriber gateways
  - high-level subscriber and CPE troubleshooting
  - interconnection with ISPs
- Business network training on:
  - firewall management
  - overview of business network software
  - DDI configuration and management
  - network and service performance monitoring

#### Adtran Response:

- The SDX BOM reflects all of the training options associated with SDX, MCP, ONT and Mosaic One (M1).
- Adtran offers numerous training options for our customers. These include Online Training, Virtual Instructor Led Training, Instructor Led Training at Adtran Corporate Training Center, and customized Onsite Training.
  - SDX OLT SWITCH COURSE
  - SDX OLT ENROLLMENT
  - MOSAIC CLOUD PLATFORM
  - MOSAIC DEVICE MGR CSR SKILLS
  - MOSAIC DEVICE MGR ADMIN
  - MOSAIC HOME ANALYTICS

Please reference the Supporting Documents for all Training Course Descriptions.

#### 4.3.6 Documentation – (Deliverables)

- Cable, panel, and equipment labeling
- Provide comprehensive documentation (format to be determined)
- Rack elevations
- Power, fiber, copper cross-connects
- Detailed layer 1 and 2 network diagrams
- Shelf level diagrams

- IP address and subnet assignments
- Electronic backups of all element configurations on portable media

Adtran Response:

ADTRAN Professional Services will provide all As-Built information for any necessary changes or deviations from the Engineering Design Package containing rack diagrams and all power and fiber connectivity assignments. All configuration information pushed to the equipment will be provided on the Low Level Design provided by the Broadband Engineer post turnup. All documentation will be packaged and handed off to the customer prior to acceptance of work.

***For purposes of this Submission, tasks marked “Onsite” should include travel in the professional services pricing. City reserves the right to coordinate with the Seller to modify the services and their delivery to reduce their overall cost.***

CITY OF SUPERIOR  
**ConnectSuperior Fiber Network Equipment and Services RFI**  
**RFQ #23-39-IT**

ADDENDUM #1

DATE: September 13, 2023

TO: Prospective Applicants

Bid Opening Date: **Tuesday, October 3, 2023, at 5:00 PM (unchanged)**

This addendum modifies the Proposal Documents for the above-listed project. The addendum consists of two (2) pages.

Clarifications:

1. **Page 3, Section 1.1. Language correction:**

The **City** wishes to contract with a **Seller** able to provide the turn-key go-live ready system specified in this **RFI**. Scope of work service requirements are more particularly identified in Section 4 of this RFI. Specifications and compatibility requirements are more particularly identified in Section **5 4** of this RFI.

2. **Question: Page 3, Section 1.1 under Purpose.** The request states the City will own and operate the network. Some model's separate ownership and operations, can you please confirm the City's intent. Is the city planning to operate the network internally or outsource operations to a 3rd party? This firm can support either scenario, however, we want to respond accordingly, our approach will vary.  
**The City intends to own the network and will consider all or partial operations of the network.**

3. **Question:** Does the City have a data center now or plan to have a data center for this project?  
**The data center for Phase 1 will be housed in the current city offices building. Please focus your response on Phase 1 only.**

4. **Question:** Does the City have enclosures, or should enclosures be included in our RFI response?  
**To clarify, if you are referring to splice enclosures, yes, the City will procure splice enclosures as part of construction. If you are referring to cabinet enclosures, or fiber distribution hubs, yes, the City will also procure these as part of construction.**

5. **Question:** What is the distance on the furthest subscribers, or rather, what is the distance on the longest fiber run? This would play a consideration in what optics are recommended for our solution.  
**We will have a more accurate footage once the LLD is complete, but at this time every customer will be able to be reached with a 20KM GPON optic.**

6. **Question:** Are all 15,000 "homes passed" within the city limits?  
**Yes.**

7. **Question:** Is Geo-Red or HA Core Required?  
**Please provide optional pricing and equipment specifications for Geo-Red and HA Core solutions as part of your bid.**

8. **Question:** Can there be 7'x23" telco racks (not just 19")?  
**The City can accommodate either 19" or 23" telco racks.**
9. **Question:** "multi-count single mode fiber rings connecting the data center, its collocated access POP, and remote access POPs to optical distribution networks (ODN) serving subscriber premises" Could you please clarify further?  
**The City will utilize a standard XGS-PON or Active Ethernet architecture with one or more POP sites and fiber distribution cabinets in the field to provide subscriber based broadband services.**
10. **Question:** Is there any stipulation on 100% aerial vs 100% buried vs a mix?  
**The network will be built with predominately underground construction with a minor amount of aerial construction on existing utility poles.**
11. **Question:** RFI does not include requirements for Subscriber WiFi. Could you please share more detail on your plan for subscriber WiFi?  
**The City would like to understand each vendor's managed WiFi solution so please include details and pricing with each bid.**
12. **Question:** Please provide projected optical path distance between locations.  
**Each customer will be able to be reached with a sub 20KM GPON optic.**
13. **Questions:** How long is the distance to the furthest sub?  
**Each customer will be able to be reached with a sub 20KM GPON optic.**
14. Interviews with vendors submitting a response to this RFI will be held October 4-6. Please reserve time.

END OF ADDENDA TEXT

[Adtran has read and understands Addenda 1](#)

## **Main Core and POP Proposal Requirements**

**The physical outside plant (OSP) architecture consists of multi-count single mode fiber rings connecting the data center, its collocated access POP, and remote access POPs to optical distribution networks (ODN) serving subscriber premises.**

**POPs will be prefabricated shelters contain a -48v DC power system, 7' x 19" equipment racks, HVAC, cable ladder, and fiber distribution panels (FDPs) with SC/APC connector profiles.**

**ConnectSuperior will maintain 2-3 POPs with 5,000 - 6,000 subscribers per POP.**

**10 and 100 gigabit access facing interfaces**

**100 gigabit cross-connect interfaces between core devices**

**10 and 100 gigabit service provider facing interfaces (for connection to retail ISPs)**

**Support for LAG and MC-LAG**

**Sub-gigabit, 1 gigabit and 10 gigabit subscriber services, scalable to 100 gigabit**

**XGS-PON or Active Ethernet access technology for subscriber-facing services**



# Proposed Network Architecture for Core, Aggregation, and PoP Sites

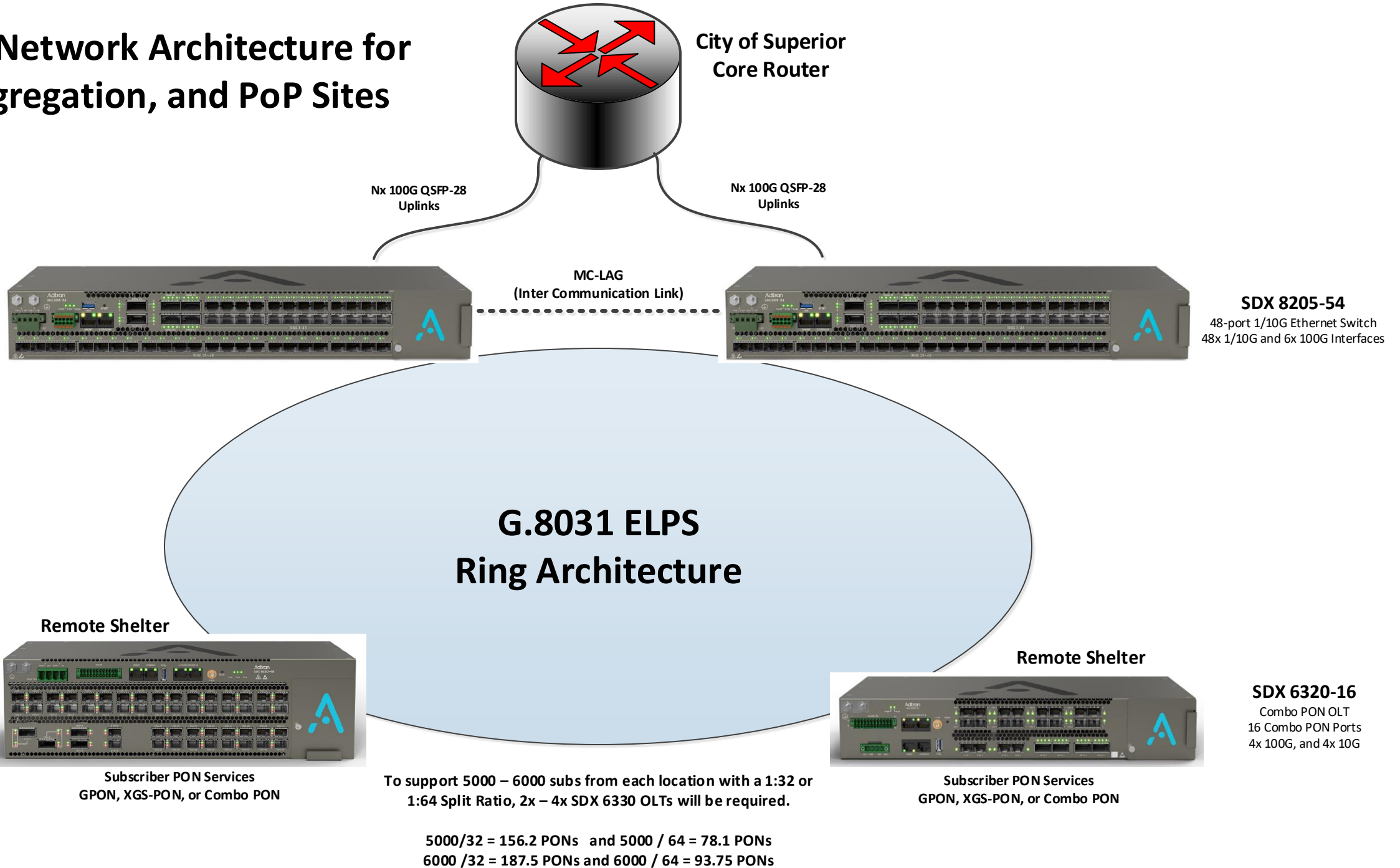

## SDX 6330 combo PON OLT

- Dimensions: D: 225mm, W: 387mm, H: 110mm (2.5RU)
- Airflow: Front/side to side (right), side removable fans (right)
- Typical power consumption w/o optics: 220W

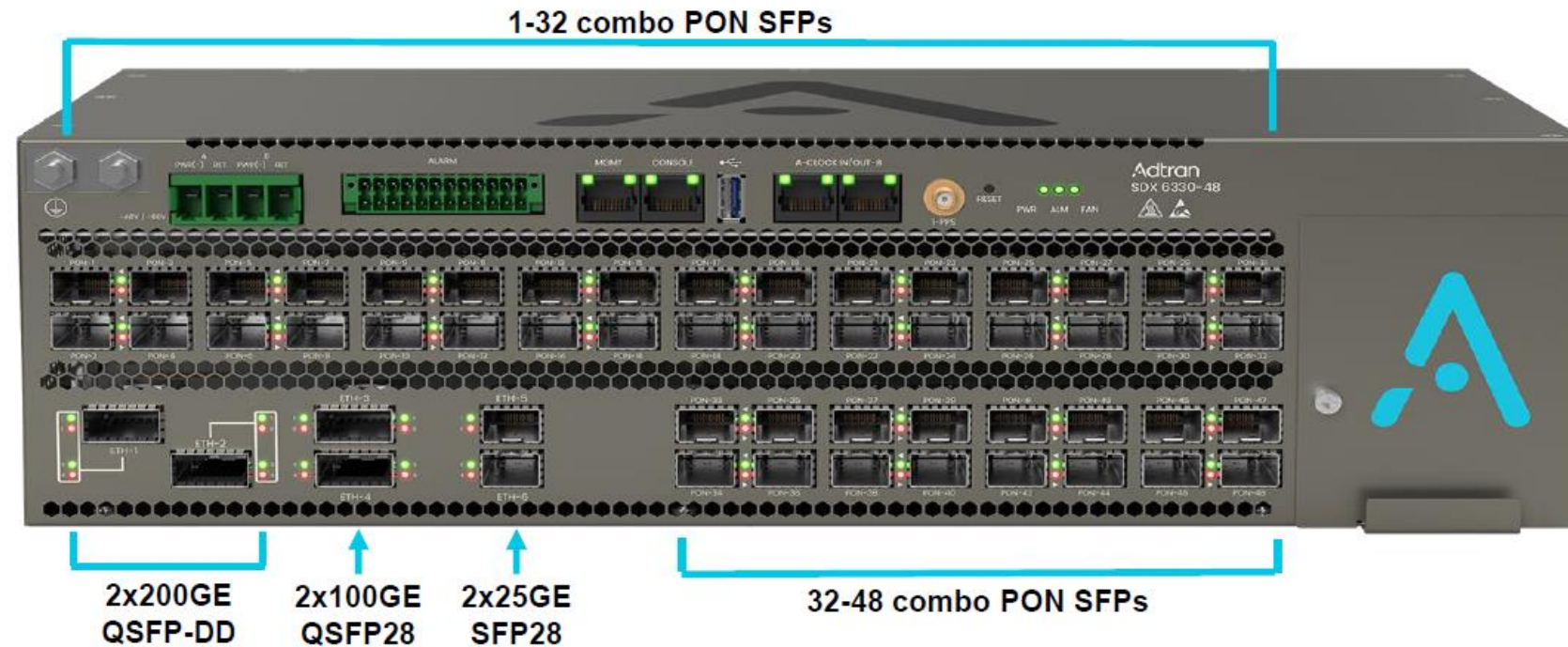

## SDX 6320 combo PON OLT

- Dimensions: D: 225mm, W: 387mm, H: 66mm (1.5RU)
- Airflow: Front/side to side (right), side removable fans (right)
- Typical power consumption w/o optics: 220W

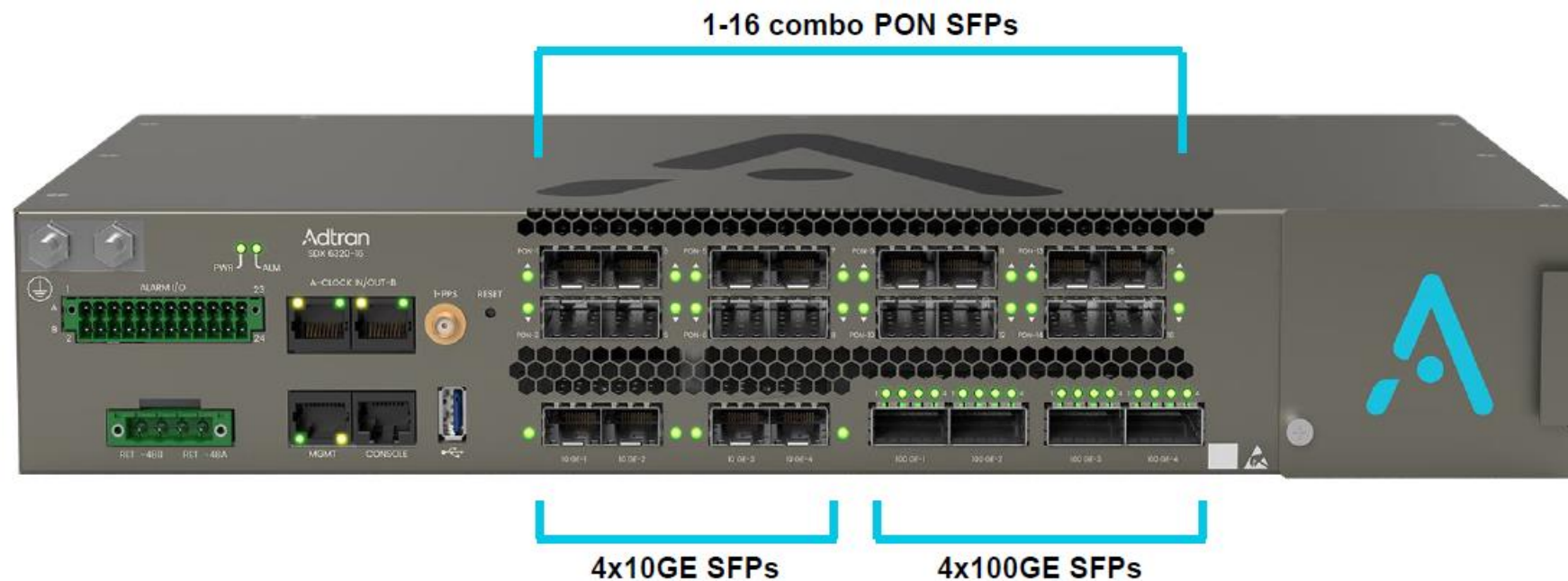



THE BEST OF BOTH WORLDS

# Combo PON explained

- Deliver symmetric multi-Gigabit services for residential, business simultaneously
- Launch both GPON and/or XGS-PON simultaneously from a single PON port
- Simplifies migration from legacy GPON to higher capacity XGS-PON

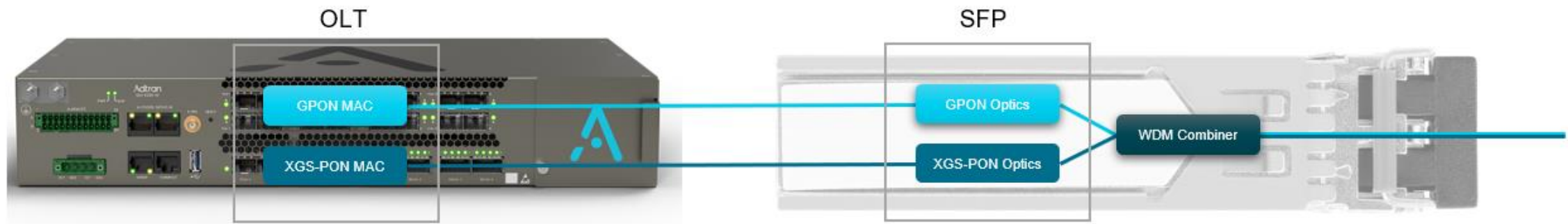
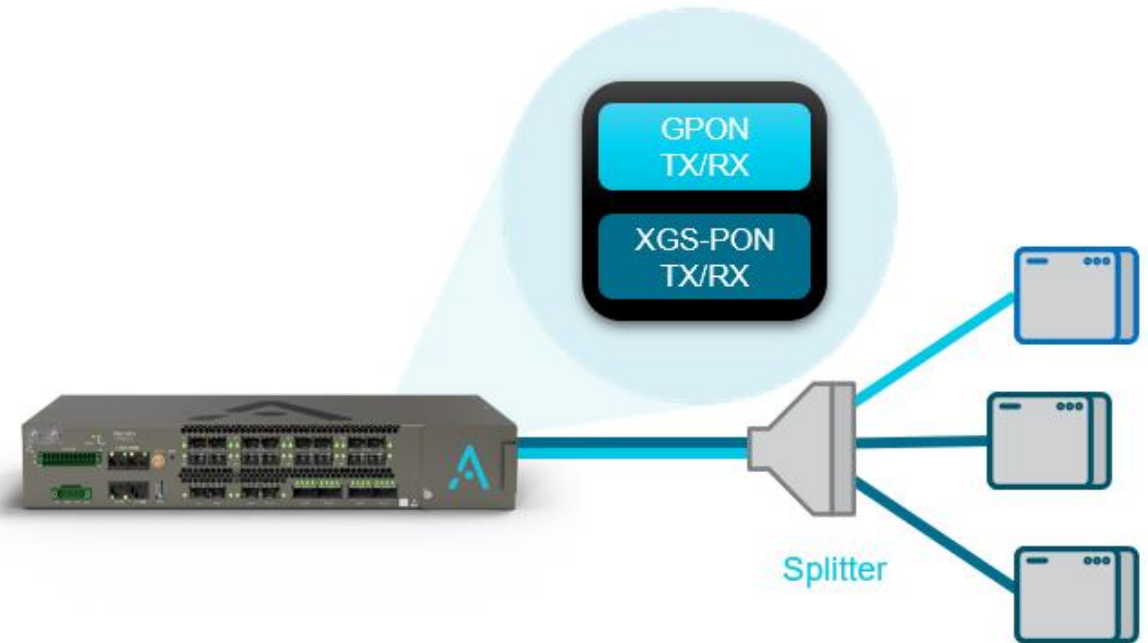

## **Main Subscriber Proposal Requirements**

### **For standard subscriber:**

**XGS-PON or Active Ethernet per vendor's solution**

**Support for indoor and outdoor options**

**1GE LAN port**

**1 POTS line**

**Wireless gateway for all-in-one ONT+Gateway functionality**

### **For large enterprise and community anchor organizations:**

**1, 10 and 100 Gigabit interfaces, both network and customer facing**

# Proposed Subscriber Options

## Standard PON termination

**SDX 6330-48**  
 Combo PON OLT  
 48 Combo PON Ports  
 2x 200G, 2x 100G, and 2x 10/25G

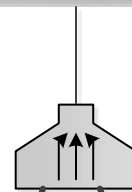
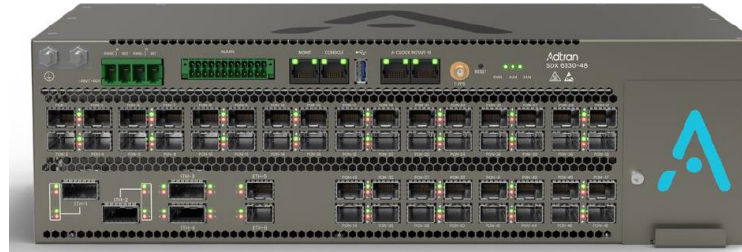

**SDX 632v**  
 XGS-PON ONT  
 2.5G UNI, 10G UNI, POTS

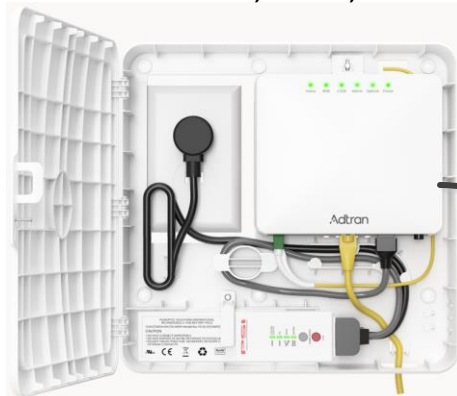

XGS-PON

XGS-PON

### XGS-PON ONT matrix – SDX 630 Series

	630	631	631q	632v	631qv	632vh	634w
<b>Housing</b>	Indoor	Indoor	Indoor	Indoor	Indoor	Outdoor	Indoor
<b>VoIP</b>				1	1	1	2
<b>2.5G UNI</b>			1	1	1	1	3
<b>10G UNI</b>	1 SFP+	1		1		1	1



SDG 8600 series  
WiFi Gateways

# Proposed Subscriber Options

## Standard 1G / 10G termination

**SDX 6330-48**  
 Combo PON OLT  
 48 Combo PON Ports  
 2x 200G, 2x 100G, and 2x 10/25G

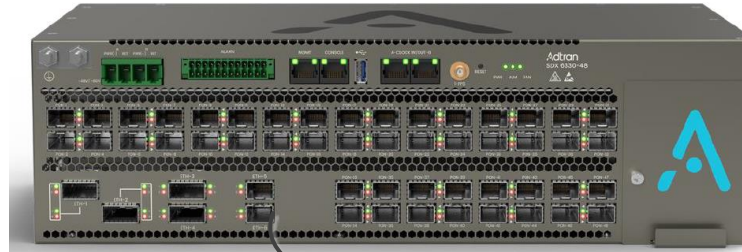

10G





**SDX 8120-14**  
 10-port 1G Ethernet Switch  
 4x 10G and 10x 1G Interfaces

10G

1G

NEW 1/10G NID

FSP 150-XG108 hardware variants

<p><b>XG108</b></p> <ul style="list-style-type: none"> <li>➢ Half-rack width</li> <li>➢ 0° C to +55° C operating temp</li> <li>➢ 1x integrated PSU – AC and DC options</li> </ul> 	<p><b>XG108 (H)</b></p> <ul style="list-style-type: none"> <li>➢ Full-rack width</li> <li>➢ -40° C to +65° I operating temp</li> <li>➢ 2x pluggable PSU</li> </ul> 
<p><b>XG108 (SH)</b></p> <ul style="list-style-type: none"> <li>➢ Full-rack width</li> <li>➢ -40° C to +65° I operating temp</li> <li>➢ 2x pluggable PSU</li> <li>➢ BITS and ToD interfaces*  <small>*Sync-E and PTP supported in future release</small></li> </ul> 	<p><b>Common for all variants</b></p> <ul style="list-style-type: none"> <li>➢ 2x 10G Network facing</li> <li>➢ 2x 10G client</li> <li>➢ 4x 1G client</li> <li>➢ Fanless</li> <li>➢ NEBS compliant</li> </ul>



**FSP 150-GE104**  
 2x GE Network Ports  
 5x GE Client Ports

# Solution Overview - SDX

## Fiber Access Solutions

October 3, 2023

### Adtran PROPRIETARY

**This document is the property of Adtran Inc. Any duplication, reproduction, or transmission to unauthorized parties without the permission of Adtran Inc. is prohibited.**

**This document represents a proposed solution for a specific application. Specific requirement implementation is conditional depending on customer approval of the solution and a mutually agreed upon development schedule.**

**Copyright © 2023 Adtran Inc.**

**ALL RIGHTS RESERVED**



## Introduction

Adtran is delighted to be invited to provide this response. We tremendously value the opportunity presented to us to demonstrate Adtran's FTTP capabilities including offering our best-in-class access solution to meet and exceed the requirements set forth.

Adtran's longstanding history in telecommunications and emphasis on customer experience has only further developed the understanding that a solution is only as great as its weakest link. Adtran has worked tirelessly to develop an end-to-end solution that begins in the customer's home or office with adaptive cloud Wi-Fi solutions. These solutions continue by traversing the network with Gigabit capability, not limited to fiber with industry standard 10 Gigabit PON technologies. Adtran's solutions continue up to Network Domain Orchestration with Mosaic One which can provision a service across the entire fabric all the way from the core to an end user's device, simplifying and expediting the provisioning procedure to increase customer satisfaction and reduce operation costs. Adtran's solutions even enable NOC personnel to constantly monitor and maintain the health of the network and enable them to perform actions proactively instead of reactively further increasing customer satisfaction.

Gigabit service delivery has traditionally meant building FTTH networks which require fiber to be pulled throughout the home. Adtran understands the common concerns for service providers evaluating Gigabit deployment options such as the overall cost to build an all-fiber network and how to keep up with subscriber activations and subsequent service or network upgrades considering growing demand. Technology breakthroughs now offer lower deployment costs, improved time to market and doubled network longevity all while supporting new service creation benefits.

Adtran offers the most open and complete 10 Gigabit broadband access portfolio on the market today. Adtran solutions optimize existing technology infrastructures and help create new, multi-gigabit platforms that leverage cloud economics, data analytics, machine learning and open ecosystems — the future of global networking.

Upgrading FTTP networks to 10G next-generation PON provides network operators the performance to extend the life of their Optical Distribution Network (ODN) while providing an architecture that supports cost-effective business and backhaul service delivery at greater than Gigabit speeds. Recent surveys have shown growing momentum for 10G fiber-based broadband networks. Research firm, Omdia, forecasts that by 2025, 10G fiber networks will serve most broadband subscribers globally.

Adtran offers ideal solutions for service providers who seek a flexible, cost-effective solution to evolve their networks and deliver a wide array of next-generation services today and into the future.

Please review the following information and feel free to let us know what questions you may have on any of the solutions presented to address any concerns.

# Mosaic One

Modern broadband networks must deliver more than high-speed connections – they must deliver an optimized customer experience powered by value-driving applications. Mosaic One is a cloud-based Software as a Service (SaaS) that aggregates AI-driven insights from network management and service orchestration applications pulling data from access network platforms and in-home devices. The result is actionable intelligence leveraged from network and user behavior insights presented in three distinct dashboard portals: **Care**, **Operate** and **Promote**.

- **Mosaic One Care** enables support teams to access a unified view of a customer's experience and utilize actionable intelligence to resolve customer issues on the first call, improving satisfaction and reducing costly escalation.
- **Mosaic One Operate** equips network engineering and maintenance teams with AI-driven insights to preemptively identify at-risk connections and alarms, reduce truck rolls, and minimize network downtime.
- **Mosaic One Promote** empowers marketing teams to easily leverage customer insights, advanced filters, and marketing platform integrations. This knowledge allows Marketers to target the right customer with the right service campaign every time.

Mosaic One offers a single sign-on experience that respectively equips customer support teams, network engineers, and marketers to quickly resolve customer issues, preempt impending network issues, and assess customer behavior to expertly guide their campaigns. With Mosaic One, service providers can spend less time running their network and more time building their brand.

## Delivering on a Great Customer Experience with Mosaic One Care

Every broadband service needs to be supported by a strong and efficient customer support department to bolster customer loyalty. Mosaic One enables customer service teams to prioritize user experience at an unprecedented level. A simple search returns a subscriber's full experience by aggregating information from multiple applications and presenting actionable intelligence to resolve customer issues on the first call, improving satisfaction without increasing OpEx.

- Troubleshoot a subscriber's connection accessing information drawn from both the entire broadband access and the in-home network with a simple search.
- Visualize quickly, by subscriber, current and recent device alarms from the access and aggregation platforms, the Wi-Fi gateways, and any other in-home devices.
- Understand customer experience with at-a-glance indicators, light level read-outs, and throughput utilization.
- Utilize actionable intelligence via AI-driven insights to identify issues and recommend resolutions – without escalation or truck rolls.

### **Maintaining a Resilient Network with Mosaic One Operate**

Unplanned network interruptions and congestion can impact subscriber satisfaction and often leads to a subscriber choosing a competing provider. In today's expanding market, it is crucial for service providers to prioritize network health. Mosaic One Operate equips network engineers with an AI-driven, forward-looking radar to monitor access and preemptively identify at-risk connections that allow operators to respond before customer interruptions ever occur.

- Audit your network to identify issues from bad fiber lights to overutilized CPU – and everything in between – and quickly assess risk severity.
- Identify the primary cause of the alarm and view recommendations for resolution quickly from AI- driven insights.
- Reduce truck rolls with actionable intelligence on each network element.
- Increase subscriber uptime and network availability by proactively correcting issues.

### **Elevating your Customer Outreach with Mosaic One Promote**

With competitors entering the market at an increasing rate, service providers must craft intelligent campaigns to stand out above the noise. Mosaic One Promote empowers marketing teams to deliver the right campaign at the right time. Customer insights, advanced filtering, and marketing platform integrations help operators:

- Increase service take-rate through promotion targeting. Analyze subscriber behavior to segment audiences and build highly targeted campaigns.
- Increase potential revenue by preemptively identifying upgrade and churn candidates.
- Maximize marketing resources by automating sophisticated cross-platform marketing campaigns.
- Craft distinctive campaigns with the help of the Adtran Marketing Center – a library of resources, refreshed frequently to always provide marketers with ready-to-brand content built by fellow telecom marketers.

### **Growing Brand Equity for Maximized Value Realization**

Mosaic One streamlines customer care, network operation, and marketing campaigns to safeguard customer loyalty and increase the bottom line through AI-driven insights and actionable intelligence.

- Mosaic One Care increases Net Promoter Score by 35 points.
- Mosaic One Operate reduces truck rolls by 50%, reducing operational expenses.
- Mosaic One Promote reduces churn by 25% and increases ARPU by 20%.
- Mosaic One helps service providers reduce their material costs and carbon footprint with AI- driven insights.

### **Make a lasting impression with curated content from Mosaic Marketing Center**

The average subscriber receives between 300 and 3000 marketing messages daily, but only retains three. Set your brand apart from the noise to grow loyalty and revenue with curated content. Act on the intelligent user analytics learned in Mosaic One Promote and choose poignant campaigns from the library of resources, ready to custom brand instantly and publish as your own. The expansive skills of a full marketing agency combined with the industry experience of broadband marketers are boxed up and ready to use for a fraction of the cost.

- Instantly customize marketing collateral, social posts, and educational content to unique branding with a simple click of a button
- Royalty-free, customizable video content for promotions and subscriber education
- Personalize content for each community with local stock photo and video services
- Request and build unique campaigns with a full-service marketing agency for no additional cost
- Improve marketing strategy with consulting hours every quarter with expert broadband marketers

### **Reach new markets and prospects with Fiber Homes from Mosaic One**

Fiber Homes brings fiber offering information to the hands of new movers and real estate agents via multiple listing service (MLS) integrations. In a matter of minutes, a fiber build-out of service addresses is correlated with the local MLS service, certifying the houses passed as Fiber Certified. This information is shared with the MLS services and major real estate websites such as Movoto or with a plug-in for Zillow.

- Reach new movers before competition by marketing fiber services on real estate listings
- Partner with local real estate agents to provide marketing and educational materials, encouraging agents to market the fiber service for free
- Rise above competitor noise with localized marketing strategies on-demand
- Grow brand equity by identifying key market growth opportunities
- Capitalize on real estate market opportunities to reach new subscribers, partner with agents, and drive community growth

### **Capture the value of the gaming community with Fiber Gaming Network from Mosaic One**

Fiber Gaming Network empowers operators to bring the power of the gaming community to the homes of their subscribers. By adding Fiber Gaming Network to standard Wi-Fi packages, operators connect subscribers to weekly, nationwide gaming events, esports recruiters and resources, a community for streaming, and weekly prizes and giveaways. All this value is professionally managed by Fiber Gaming Network, allowing operators to provide a great gaming experience, without increasing the labor of their staff.

- Increase average revenue per user with a gaming platform, increased packages, and advanced gateways, gaining value from the untapped gaming community within the subscriber base.
- Build quality relationships with the local schools with resources to create, manage, and run esports leagues.
- Connect local esports gamers and schools with college recruiters through an exclusive Discord channel and college directory – with scholarship listings.
- Improve targeted campaigns with advanced analytics on gamers – both current customers and prospects – combined with ready-to-brand content in the Mosaic Marketing Center.

# Network Management

Mosaic Cloud Platform is our SDN control and orchestration solution. Mosaic Cloud Platform has been embraced by the most progressive global service providers, offering an open, scalable, multi-vendor end-to-end service orchestration solution.

## Adtran Mosaic Software Suite

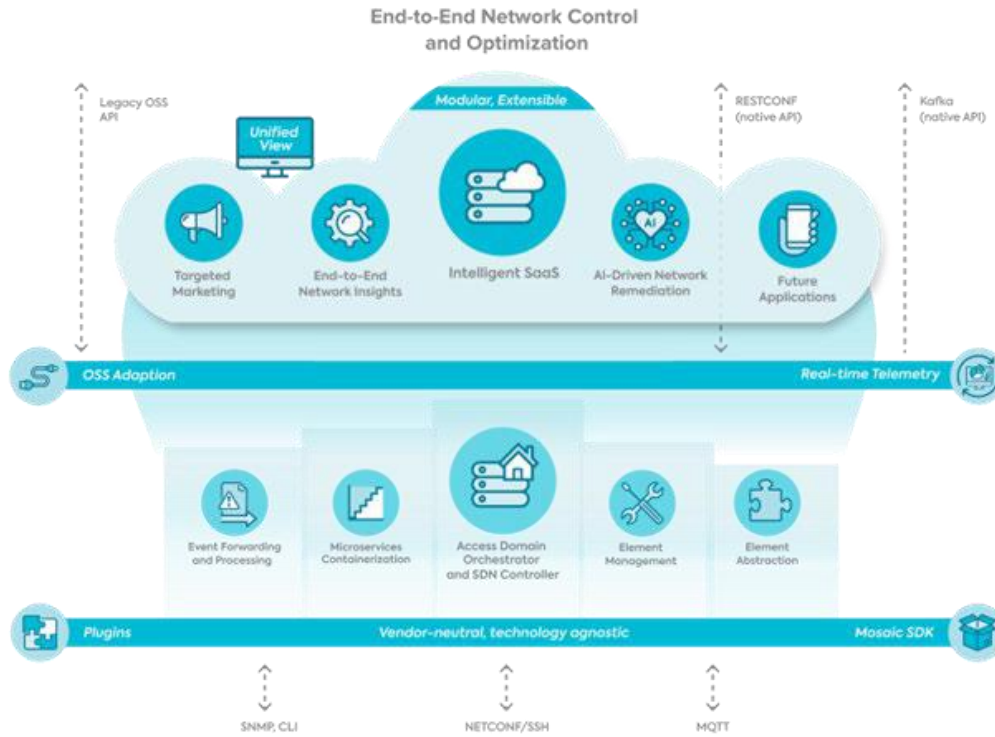

Mosaic Cloud Platform provides Service Providers with an evolution from vendor-specific element management systems using semi-automated provisioning of individual access technologies to support fully automated orchestration and SDN control of multi-vendor, multi-technology networks. Adtran's Network Management is built to tackle functions ranging from orchestration of fiber access systems, OSS adapters, traditional fault, configuration, accounting, performance, and security (FCAPS) functions or advanced data mining analytics.

## Solution Overview

Adtran's SDX architecture is the ideal solution to support the XGS-PON Fiber Access and FTTP infrastructure for the next decade and beyond. This document serves as an introduction and short overview of the platform we are proposing in this response. Detailed information is contained in the Bill of Material (BOM) response along with the supporting documents.

Adtran began developing open, disaggregated fiber access systems more than five years ago. These next-generation fiber systems are built upon the same architectural principles and economies

of scale that underpin today's massively scalable data center architectures, adapted for the unique requirements of access networks.

## Flexible Architecture

Rather than reusing a traditional, monolithic chassis system, or simply porting that chassis software to disaggregated hardware, Adtran's SDX 6000 series uses a modern, modular software architecture for both programmable network elements and associated cloud software. By using this approach, Adtran's SDX 6000 OLTs are uniquely capable of being deployed as an integrated system with traditional, embedded management and control planes, or as a fully disaggregated system with cloud-based control from open-source platforms like ONOS and VOLTHA.

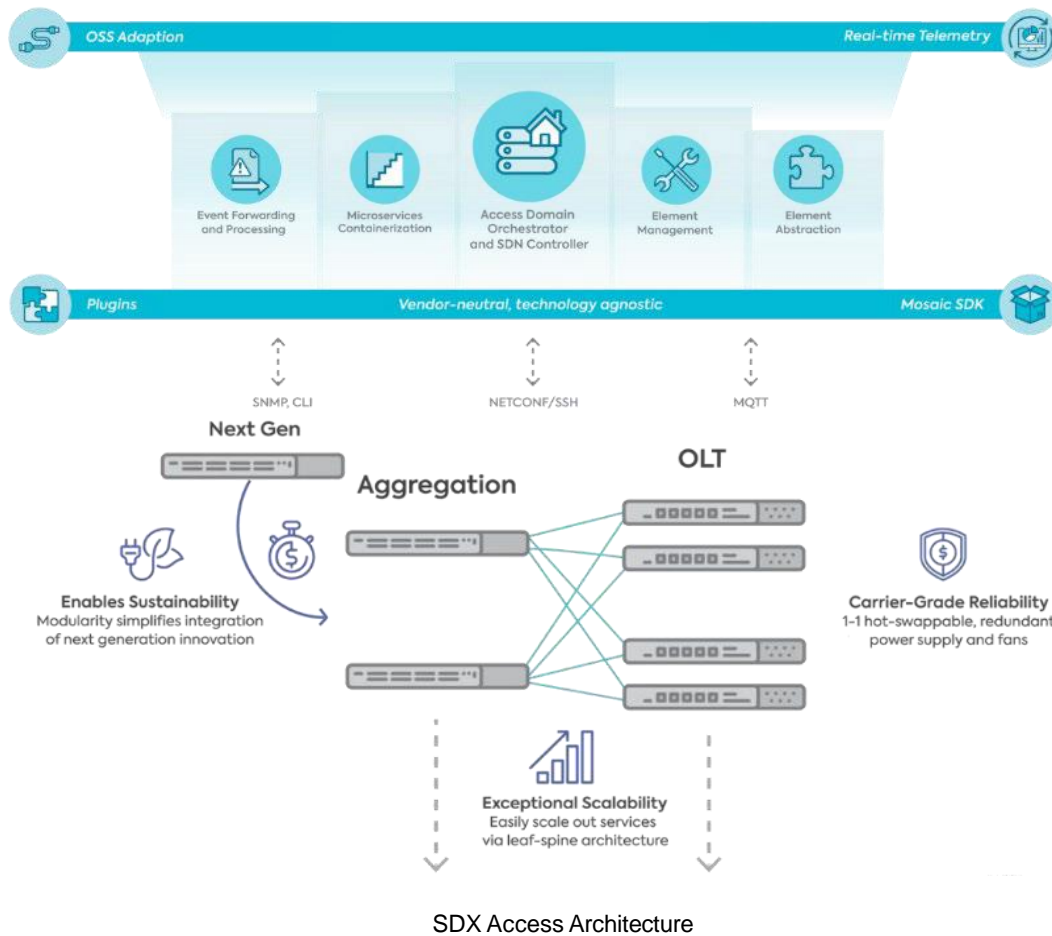

### Centralized, High-scale Rack-mount OLTs

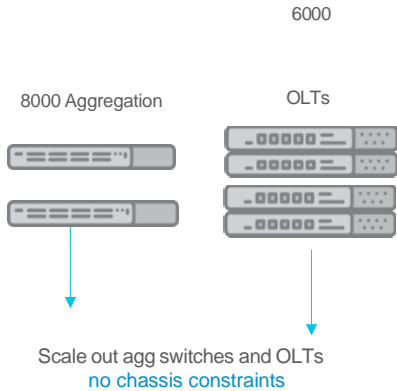

### Distributed, Low-port Remote OLTs

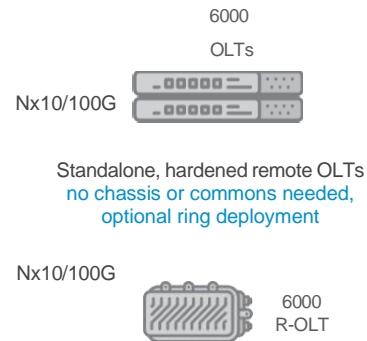

Unmatched scalability – scale-up or scale-down

This combination of flexibility and scalability makes SDX a compelling architecture.

SDX is built from the ground up as a modern solution, with a NETCONF core and the accompanying YANG-modeled configuration as the native data store of the platform. There is no modern “shim layer” interface layered on top of a legacy core that limits flexibility and constrains both performance and future growth. It is also free from the physical scaling constraints of a chassis platform, scaling down to a single clamshell or pizza box without requiring common elements like a chassis shell, switch cards, and fan trays. SDX also scales up linearly without the constraints of a chassis form factor, limited only by the speed and quantity of Ethernet interconnects, both of which can increase with the advent and deployment of new technology – without stranding or obsoleting any previous investment. Service providers today are building single-location SDX systems with almost 2,000 OLT ports, serving nearly 50,000 subscriber locations.

### Solution Components

The Adtran solution set for next generation fiber access systems includes a full range of programmable network elements, control plane, and management plane software components that complement open-source platforms, along with turnkey systems integration services. This offering allows Adtran to cover all aspects of design, integration, and field deployment of vOLT fiber access systems.

For this opportunity, Adtran recommends the SDX solution, which includes our disaggregated OLTs and our Mosaic Cloud Platform software” should change to “For this opportunity, Adtran recommends the SDX solution, which includes our disaggregated OLTs, our family of ONTs, the Service Delivery Gateway for exceptional in-home WIFI experience, and our Mosaic One software used to provision, monitor, and troubleshoot the network from the core through the door. Together, these components offer the Service Provider the software, equipment, and tools necessary to provide an excellent customer experience for both the 3<sup>rd</sup> party service providers who will ride your network as well as the end users who take their services.

**Disaggregated OLTs** – Adtran leads this response with the SDX 6330-48, a high-density, temperature-hardened 48-port pizza box OLT that can be deployed in core sites, huts, or street cabinets. The SDX 6320-16 packs all of the same features into a 16-port pizza box form factor for locations where fewer ports are needed. Additionally, the SDX 6312-4, a 4-port environmentally-hardened “clamshell” is available for lower density outside plant deployments. Datasheets for these OLTs can be found in the supporting documents.

**Mosaic Cloud Platform** – Mosaic CP is Adtran’s SDN control and orchestration platform. It is a modular, microservices-based software platform that includes targeted management plane and control plane applications that complement open source SDN controllers where needed. Mosaic CP includes functionality that addresses feature sets like Access Domain Orchestration for disaggregated access systems, FCAPS/EMS feature sets, subscriber session management, and OSS API adapters. Mosaic CP’s open interfaces and SDK for physical network elements and software applications make it the ideal platform to place at the center of next generation, distributed access architectures powered by commercial and/or white box network elements.

## OLT Platform Details

All Adtran’s OLTs come with a full set of features that are required in a modern broadband access network including but not limited to:

- Full TR-101/156 and OMCI feature set
- 32k multicast groups to support multiple video content providers
- Integrated traffic management
- SyncE and IEEE1588 hardware-capable
- NETCONF/YANG APIs for SDN programmability



## SDX 6330-48 Combo OLT

The SDX 6330-48 brings XGS-PON + GPON combo capability for maximum flexibility. It brings the same feature set as the SDX 6312-4, but in a pizza box form factor with higher port count, optimized for higher port density and lower power consumption per port. The SDX 6330-48 is ideal for higher-density cabinet, hut, or headend sites.

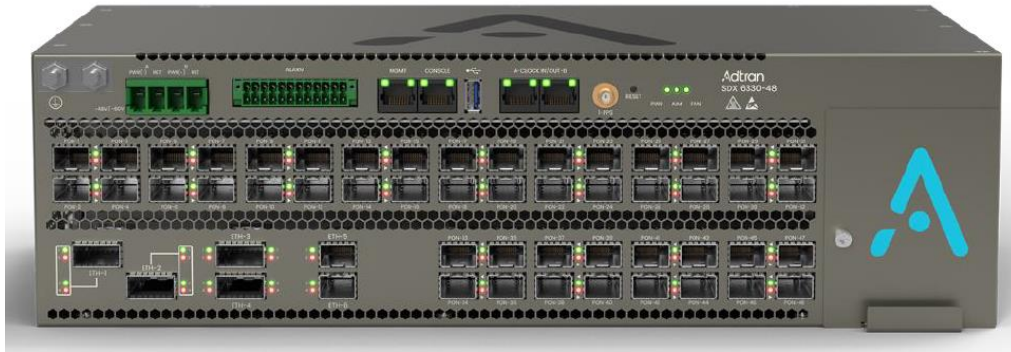

Pizza Box OLT SDX 6330-48

- 48 x SFP+-based 10G PON ports, supporting XGS-PON and GPON
- Capable of supporting the following on a per port basis:
  - GPON via GPON OLT SFP
  - XGS-PON via XGS-PON OLT SFP+
  - Combo PON (XGS-PON and GPON simultaneously) via Combo OLT SFP+
- Supports up to 1:128 split per port
- 2x200G QSFP-DD ports, 2x100G QSFP28 ports, 2x25G SFP28 ports
- Temperature hardened for -40 to +65C operation
- Ships with 19 in. rack mount kit, (265mm depth) at 2.5 RU height. 21 in. and 23 in. rack mount kits are available.
- Flexible airflow options
- Generally available today for production deployments

## SDX 6320-16 Combo OLT

For cabinet, hut, or headend sites with more modest port count needs, the SDX 6320-16 packs all of the features of its bigger brother into a 16-port pizza box to right-size your access infrastructure to match the requirements of each location in the network.



Pizza Box OLT SDX 6320-16

- 16 x SFP+-based 10G PON ports, supporting XGS-PON and GPON
- Capable of supporting the following on a per port basis:
  - GPON via GPON OLT SFP
  - XGS-PON via XGS-PON OLT SFP+
- Combo PON (XGS-PON and GPON simultaneously) via Combo OLT SFP+
- Supports up to 1:128 split per port
- 4x100G QSFP28-based uplink ports, also capable of 10 & 40G operation
- 4x10G SFP+ uplink ports, also capable of 2.5Gbps and 1Gbps
- Non-blocking uplink capacity with 400G
- Temperature-hardened for -40 to +65C operation
- Ships with 19 in. rack mount kit, (<265mm depth) at 1.5 RU height. 21 in. and 23 in. rack mount kits are available.
- Flexible airflow options
- Generally available today for production deployments

## SDX 6324-4 Combo OLT

For cabinet, hut, or headend sites with more modest port count needs, the SDX 6324-4 packs all of the features of its bigger brother into a 4-port pizza box to right-size your access infrastructure to match the requirements of each location in the network.



Pizza Box OLT SDX 6324-4

- 4 x SFP+-based 10G PON ports, supporting XGS-PON and GPON
- Capable of supporting the following on a per port basis:
  - GPON via GPON OLT SFP
  - XGS-PON via XGS-PON OLT SFP+
- Combo PON (XGS-PON and GPON simultaneously) via Combo OLT SFP+
- Supports up to 1:128 split per port
- 4x10G SFP+ uplink ports, also capable of 2.5Gbps and 1Gbps
- Non-blocking uplink capacity with 40G
- Temperature-hardened for -40 to +65C operation
- Ships with 19 in. rack mount kit, (<265mm depth) at 1 RU height. 21 in. and 23 in. rack mount kits are available.
- Flexible airflow options
- Generally available today for production deployments

## SDX 6312-4 Sealed Combo OLT

To support remote network deployments, Adtran has introduced the sealed combo OLT platform. It provides 4x10Gbps uplinks with 4 Combo PON ports that are capable of either GPON, XGS-PON or both simultaneously with the appropriate Combo optics. Utilizing gray, CWDM, or DWDM SFP+ uplinks, the Remote OLT can be deployed in outside locations, from strand mount, wall mount, or even underground locations with a hardened temperature profile of -40 to +65C and waterproof enclosure.



Outdoor OLT SDX 6312-4

- 4 x SFP+-based 10G PON ports, supporting XGS-PON and GPON
- Capable of supporting the following on a per port basis:
  - GPON via GPON OLT SFP
  - XGS-PON via XGS-PON OLT SFP+
  - Combo PON (XGS-PON and GPON simultaneously) via Combo OLT SFP+
- Supports up to 1:128 split per port
- 4x10G SFP+ uplink ports, also capable of 2.5Gbps and 1Gbps
- CWDM and DWDM uplink support for fiber-poor or very remote locations
- Non-blocking uplink capacity for GPON or XGS-PON
- Temperature hardened for -40 to +65C operation
- AC, DC, and 90V CATV power options
- Generally available today for production deployments

## Customer Premises Equipment

Adtran's suite of residential CPE includes our latest Wi-Fi 5/6 Service Delivery Gateways, Mesh Wi-Fi, and a comprehensive portfolio of indoor and outdoor XGS-PON and GPON ONTs. Plus, Mosaic One, our cloud-based management tools further optimize the subscriber experience while reducing complexity in the home network.



### **SERVICE DELIVERY GATEWAYS**

Our Wi-Fi 6 enabled gateways are designed to offer consistent, high-speed performance combined with low latency in congested networks. OpenSync integrated.



### **XGS-PON ONTs**

10G ONTs supporting (XGS- PON) flexible optics approach allowing service providers to support existing FTTH subscribers, facilitating deployment in current and next- gen software-defined access (SD-Access) networks.

# Residential Gateways

Adtran Residential Gateways are fully integrated service delivery platforms that optimize the subscriber experience while reducing complexity in the home network. Do not get locked into the wrong hardware; leverage the power of Adtran and enjoy best-of-breed silicon components in every home.



## RELIABLE PERFORMANCE

Our Mosaic One platform offers one CPE solution used for multiple deployment models and value-added services, giving ISPs greater flexibility and speed to market.



## SELF-INSTALL SOLUTIONS

Ship hardware directly to the customer to reduce truck rolls, improve customer lifetime value, and provide greater self-service capabilities.



## CUTTING EDGE EXPERIENCE

Get the ultimate experience with 12 streams of Wi-Fi 6 and speeds up to 6Gbps. Enjoy 4K/8K UHD streaming, lag-free gaming & smooth streaming.



## EXCEPTIONAL WI-FI INNOVATION

Transformational connectivity for next generation experiences. Enables multi-gigabit per second speeds, additional spectrum, and reduced latency.

### SDG PORTFOLIO

### SDG 800 Series (Hardware)

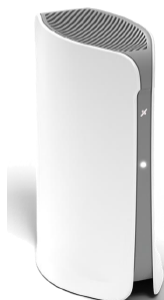

	Model	Wi-Fi	WAN	LAN	2.4GHz	5GHz <sup>1</sup>	5GHz <sup>2</sup>
Dual-band Wi-Fi 5	834-5	Wi-Fi 5	1 GbE	4 x GbE	4x4	4x4	-
	834-v6	Wi-Fi 6	1 GbE	4 x GbE 1 x Voice	2x2	2x2	-
Dual-band Wi-Fi 6	854-6	Wi-Fi 6	2.5GbE (SFP+ / Ethernet)	4 x GbE	4x4	4x4	-
	854-v6	Wi-Fi 6	2.5GbE (SFP+ / Ethernet)	4 x GbE 2 x Voice	4x4	4x4	-
Tri-band Wi-Fi 6	841-t6	Wi-Fi 6	2.5GbE	2.5GbE or 1 x GbE	2x2	2x2	4x4

BUILT FOR THE MULTIGIGABIT ERA  
**SDG 86xx Series**

Multigigabit-ready (wireless and wired)

- Two Dual-band, 4-port RGs
- Two Tri-band, 2-port AP/RG, one with 6E

	Model	Wi-Fi Gen	WAN	LAN	2.4GHz	5GHz <sup>1</sup>	5GHz <sup>2</sup>	6GHz
6ax DB	8612	Wi-Fi 6	2.5GbE	2.5GbE + 3x GbE	4x4	4x4	-	-
	8614	Wi-Fi 6	SFP+ (2.5Gbps)	2.5GbE + 3x GbE	4x4	4x4	-	-
6ax TB	8622	Wi-Fi 6	2.5GbE	2.5GbE	4x4	4x4	4x4	-
6axE TB	8632	Wi-Fi 6E	2.5Gbe	2.5Gbe	4x4	4x4	-	4x4



# Intellifi is...

**A Connected Home solution**

**Developed by... Adtran for SmartOS**

**Delivers... an excellent Wi-Fi/Internet experience**

**With... CSP Remote Management**

**And... Subscriber mobile app**

**That is... Cost-effective | easy-to-deploy | easy-to-manage**

SOLUTION OVERVIEW

**Intellifi is a Solution by Adtran**

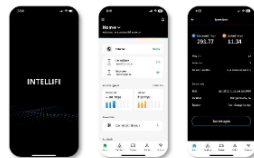

**Service Delivery Gateways (SDG)**

- 1<sup>st</sup> Gen and 2<sup>nd</sup> Gen SDGs
- SmartOS 12.x and later

**Mobile App**



- Subscriber Interface
- Android / iOS Mobile App

**Intellifi Cloud, Mosaic One**

- Service provider portal
- Integrated into Mosaic One

## Optical Network Terminals

Adtran ONTs are designed to address the market with industry leading voice, data, and video capabilities. With several different 10G PON ONT options, carriers can benefit from high data rates of fiber optic transmission and the flexibility offer by Adtran's portfolio of Ethernet-based systems that can be easily configured for new, customized service offerings.



### ULTRA HIGH SERVICE DENSITY

SD-Access networks are highly agile with the automation and scalability needed to support mass market residential service deployments.



### EXPAND NETWORK CAPABILITY

Next generation architectures offer both the capacity and scale to economically support Gigabit services, as well as multi-gigabit demands well into the future.



### SERVICE AWARE PROVISIONING

Simplifying the network by eliminating overbuilds leads to improving your operational efficiency while lowering cost.



### REMOTE MANAGEMENT

Manage an end-to-end PON deployment with advanced productivity tools for monitoring, troubleshooting, provisioning, and upgrading networks.

## GPON ONT Matrix – 400 Series

	401	411	424	452	454
<b>Housing</b>	Indoor	Indoor	Indoor	Outdoor	Outdoor
<b>VoIP</b>	-	1	2	2	4
<b>1G UNI</b>	1	1	4	2	4
<b>OLT Support</b>	TA5K	TA5K/SDX	TA5K	TA5K	TA5K
<b>Availability</b>	GA	GA	GA	GA	GA
<b>Part Number</b>	1287786F1	1287787F1	1287835F1	1287802F1	1287803F1



## GPON ONT matrix – SDX 600/610 Series

	610 (F3)	611	611q	614	601qv
<b>Housing</b>	Optic	Indoor	Indoor	Indoor	Indoor
<b>VoIP</b>					1
<b>1G UNI</b>	1	1		4	
<b>2.5G UNI</b>			1		1
<b>OLT Support</b>	TA5K, SDX	TA5K, SDX	TA5K, SDX	TA5K, SDX	TA5K, SDX
<b>Additional Features</b>	SFP ONT	Eth OAM	Eth OAM	Eth OAM	Eth OAM US/intl voice
<b>Availability</b>	GA	GA	GA	GA	Sept ONT 12.4.1
<b>Part Number</b>	1442535F3	1287933Fx*	1287934Fx*	1287842Fx*	1287987Fx*

## XGS-PON ONT matrix – SDX 630 Series

	630	631	631q	632v	631qv	632vh	635w
<b>Housing</b>	Indoor	Indoor	Indoor	Indoor	Indoor	Outdoor	Indoor
<b>VoIP</b>				1	1	1	2
<b>2.5G UNI</b>			1	1	1	1	4
<b>10G UNI</b>	1 SFP+	1		1		1	1
<b>Availability</b>	GA	GA	GA	GA	GA	Q4 2023 ONT 12.5	Q1 2024 ONT 24.1
<b>Part Number</b>	1287940F1	1287930Fx*	1287944Fx*	1287943Fx*	1287937Fx*	1287955Fx*	1287946Fx*

## 1G / 10G P2P Network Termination Units

Adtran's FSP 150 packet edge and aggregation transport solution enables you to deliver MEF-certified Carrier Ethernet services and IP connectivity with carrier-class performance, 100G scalability and highest security in a most resilient way. Whether you're offering mobile backhaul, business services, or wholesale access, our FSP 150 family is the market's first ubiquitous metro access platform that enables profitable and differentiated connectivity services scaling from Mbit/s to 100Gbit/s. Designed for demarcation, aggregation and hosting of software appliances, our solution is optimized for cost-efficient transport over fiber, copper and TDM networks.

Our FSP 150-GE100 Series is designed for intelligent service demarcation at the edge of the network. Each aspect of this series is built for cost-effective delivery of assured fiber-based Carrier Ethernet services for mobile backhaul and wholesale Ethernet applications. The series of ultra-compact first-mile demarcation devices provides a full range of multi-rate-capable Ethernet interfaces. Temperature-hardened design with no moving parts and optional network link protection, our FSP 150-GE100 Series ensures the highest service availability even in harsh environments.

## FSP 150-GE104

### 1 RU Half Rack-Width Chassis

#### Integrated PSU:

- AC: 110/240 V, DC48: -38 to -72
- nominal 19 W, maximum 25 W

#### GE Network ports

- 1 dedicated, 1 configurable
- SFP
- Protection options
  - Independent Operation
  - LAG Active/Standby
  - G.8032 Ethernet Ring Protection

### GE Client ports

- 4 dedicated, 1 configurable
- Dual media: SFP or RJ45
- Protection options: LAG Active/Standby

### MAC Learning/bridging

64EVC \* 4 CoS , 512 policers, 64

MEP/MIP

### Commercial Temp





Site connectivity is rapidly growing from 1Gbit/s to 10Gbit/s interface speeds as 5G New Radio equipment is introduced in mobile networks, digitized cable networks move to remote PHY devices and businesses push huge amounts of data into the cloud. This makes robust and reliable demarcation technology essential. These devices also need to be compact and cost-efficient as operators look to seamlessly extend bandwidth services from 1Gbit/s to 10Gbit/s.

Our FSP 150-XG108 Series provides both 1Gbit/s and 10Gbit/s services in a 1Gbit/s footprint.

NEW 1/10G NID

## FSP 150-XG108 hardware variants

<p><b>XG108</b></p> <ul style="list-style-type: none"> <li>➢ Half-rack width</li> <li>➢ 0° C to +55° C operating temp</li> <li>➢ 1x integrated PSU – AC and DC options</li> </ul> 	<p><b>XG108 (H)</b></p> <ul style="list-style-type: none"> <li>➢ Full-rack width</li> <li>➢ -40° C to +65° I operating temp</li> <li>➢ 2x pluggable PSU</li> </ul> 
<p><b>XG108 (SH)</b></p> <ul style="list-style-type: none"> <li>➢ Full-rack width</li> <li>➢ -40° C to +65° I operating temp</li> <li>➢ 2x pluggable PSU</li> <li>➢ BITS and ToD interfaces*</li> </ul> <p><small>*Sync-E and PTP supported in future release</small></p> 	<p><b>Common for all variants</b></p> <ul style="list-style-type: none"> <li>➢ 2x 10G Network facing</li> <li>➢ 2x 10G client</li> <li>➢ 4x 1G client</li> <li>➢ Fanless</li> <li>➢ NEBS compliant</li> </ul>

## Adtran SDX PON OLT and Aggregation Bill of Materials

City of Superior - Option 1

9/29/2023

**XGS-PON**  
**1G/10G P2P Optional**  
**6000 subs initially each Remote**

		Proposed Price	Main Site MC-LAG to Core	Remote / POP 6000 Subs XGS-PON 1:64 Split	Remote / POP 6000 Subs XGS-PON 1:64 Split	Spares	Total QTY	Total Price	Standard Warranty Days	Maximum Days Hardware Repair **
			QTY	QTY	QTY	QTY				
<b>SDX 8205-54, 48x10G + 6x100G Agg Switch, Includes Fan and 19" RM Kit</b>										
11971221F1	SDX 8205-54 10G S2S NO MACSEC	\$7,650.00	2	0	0	0	2	\$15,300.00	365	1095
11971503F01	SDX DB9 TO RJ45 CABLE 5M	\$13.75	1	0	0	0	1	\$13.75	365	365
11971505F1	SDX GND CBL DBL LUG 10 AWG (NA)	\$37.50	2	0	0	0	2	\$75.00	365	365
11971504F2	SDX DC PWR CBL 3M 12AWG NA	\$52.00	4	0	0	0	4	\$208.00	365	365
<b>SDX 8120-14, 10G CE SWT/RTR (Optional if doing 1G / 10G P2P at Remote / POPs)</b>										
11971230F1	SDX 8120-14 10G CE DC	\$3,410.00	0	0	0	0	0	\$0.00	365	1095
11971309F1	19IN RACK KIT	\$35.75	0	0	0	0	0	\$0.00	365	365
11971503F01	SDX DB9 TO RJ45 CABLE 5M	\$13.75	0	0	0	0	0	\$0.00	365	365
11971505F1	SDX GND CBL DBL LUG 10 AWG (NA)	\$37.50	0	0	0	0	0	\$0.00	365	365
11971504F2	SDX DC PWR CBL 3M 12AWG NA	\$52.00	0	0	0	0	0	\$0.00	365	365
<b>SDX 8000 series Device Software License - mandatory for each SDX Node you quote - selection depends on device and application</b>										
119711SW04F1	SDX 82XX L2CE 10G LIC BASE + CE: ELAN, ELINE, EOAM, ELPS, MC-LAG (Applicable to 8120-14 and 8205-54)	\$3,995.00	2	0	0	0	2	\$7,990.00	90	90
<b>SDX 8000 series 1G and 10G optics to FSP-150 Termination Devices</b>										
1184561PG3	SFP GIGE 850NM MMF SHORT	\$90.00	0	0	0	0	0	\$0.00	365	1095
1184561PG1	SFP GIGE 1310NM SMF 10KM	\$57.75	0	0	0	0	0	\$0.00	365	1095
1442401G1	SFP+ 10G MMF	\$76.45	0	0	0	0	0	\$0.00	365	365
1442410G1	SFP+ 11.3G 1310NM SMF 10KM	\$98.00	0	0	0	0	0	\$0.00	365	365
<b>40G / 100G Cabling and Optics for Uplinks and Aggregation</b>										
1445010F3C	DAC QSFP28 100G 3M	\$150.00	3	0	0	0	3	\$450.00	365	820
1445019F3C	AOC QSFP28 100G 3M	\$625.00	0	0	0	0	0	\$0.00	365	820
1445510F1C	QSFP28 100G SR4	\$350.00	0	0	0	0	0	\$0.00	365	820
1445510F2C	QSFP28 100G LR4 10KM	\$1,800.00	0	0	0	0	0	\$0.00	365	820
1445513F1	QSFP28 100G ER4L 30K ITEMP	\$7,914.50	0	0	0	0	0	\$0.00	365	820
<b>SDX 6320-16, Combo PON OLT - Includes Fan and 19" RM Kit (Optional at Smaller Sub Count Remotes / POPs)</b>										
11971330F1	SDX 6320-16 COMBO PON OLT	\$7,500.00	0	0	0	0	0	\$0.00	365	1095
11971503F01	SDX DB9 TO RJ45 CABLE 5M	\$13.75	0	0	0	0	0	\$0.00	365	365
11971505F1	SDX GND CBL DBL LUG 10 AWG (NA)	\$37.50	0	0	0	0	0	\$0.00	365	365
11971504F2	SDX DC PWR CBL 3M 12AWG NA (Need Qty = 2 for Redundant Power Feeds)	\$52.00	0	0	0	0	0	\$0.00	365	365
<b>SDX 6330-48, Combo PON OLT - Includes Fan and 19" RM Kit</b>										

11971340F1	SDX 6330-48 COMBO PON OLT	\$19,950.00	0	2	2	0	4	\$79,800.00	365	1095
11971503F01	SDX DB9 TO RJ45 CABLE 5M	\$13.75	0	1	1	0	2	\$27.50	365	365
11971505F1	SDX GND CBL DBL LUG 10 AWG (NA)	\$37.50	0	2	2	0	4	\$150.00	365	365
11971504F2	SDX DC PWR CBL 3M 12AWG NA (Need Qty = 2 for Redundant Power Feeds)	\$52.00	0		4	0	4	\$208.00	365	365
<b>SDX 6000 series PON Optics (Using a 1:64 PON Split Ratio) for 6000 subs</b>										
1442543F2	SFP+ COMBO OLT ITEMP D2	\$375.00	0	94	94	0	188	\$70,500.00	365	365
1442544F2	SFP+ XGS OLT N2 1577/1270 ITEM	\$340.00	0	0	0	0	0	\$0.00	365	365
<b>SDX 6000 series Device Software License - mandatory for each SDX Node you quote - selection depends on device and PON application</b>										
119713SW11F1	<b>SDX 6XXX COMBO PON OLT LIC</b> This is the base SW license the enables both GPON and 10G ONTs. (SDX 6320-16)	\$2,200.00	0	0	0	0	0	\$0.00	90	90
119713SW10F1	<b>SDX 6XXX XGS-PON OLT LIC</b> This is the base SW license the enables 10G ONTs. (SDX 6320-16)	\$1,800.00	0	0	0	0	0	\$0.00	90	90
119713SW13F1	<b>SDX 6XXX COMBO PON OLT HD LIC</b> This is the base SW license that enables both GPON and 10G ONTs on the high-density SDX OLT (SDX 6330-48).	\$6,600.00	0	2	2	0	4	\$26,400.00	90	90
119713SW14F1	<b>SDX 6XXX XGS-PON OLT HD LIC</b> This is the base SW license that enables 10G ONTs on the high-density SDX OLT (SDX 6330-48).	\$5,400.00	0	0	0	0	0	\$0.00	90	90
								\$201,122.25		

**\*\* Max Days Hardware Repair** - this is the maximum amount of time the device can be under standard warranty, and then hardware repair through purchase of network care.

Example, if a product has a standard warranty of 365 days, the Max Days Hardware Repair states 770 - this means that you could purchase hardware repair through Network Care for 365 days for this device.

## Adtran SDX PON OLT and Aggregation Bill of Materials

City of Superior - Option 1

**XGS-PON**  
**Support for indoor and outdoor options 1GE**  
**LAN port 1 POTS line**  
**Wireless gateway for all-in-one ONT+Gateway**  
**functionality**

		Proposed Price	Main Site MC-LAG to Core QTY	Remote / POP 6000 Subs XGS-PON 1:64 Split QTY	Remote / POP 6000 Subs XGS-PON 1:64 Split QTY	Spares QTY	Total QTY	Total Price	Standard Warranty Days	Maximum Days Hardware Repair **
<b>SDX 600 series XGS-PON ONT</b>										
1287940F1	SDX 630 SFP+ XGS-PON ONT	\$110.00	0	0	0	0	0	\$0.00	365	760
1287930F1	SDX 631 - NA 1x 10GE	\$105.00	0	0	0	0	0	\$0.00	365	760
1287944F1	SDX 631q - NA 1x 2.5GE	\$85.00	0	0	0	0	0	\$0.00	365	760
1287937F1	SDX 631qv - NA 1x 2.5GE / SIP POTS	\$96.00	0	0	0	0	0	\$0.00	365	760
1287943F1	SDX 632v - NA 10GE/2.5GE/1POTS (Molex)	\$110.00	0	0	0	0	0	\$0.00	365	760
1287955F1	SDX 632vh - NA 10GE/2.5GE/1POTS (Molex)	\$225.00	0	0	0	0	0	\$0.00	365	760
1287440F1	SDX 631 FIBER TRAY WHITE	\$19.25	0	0	0	0	0	\$0.00	365	365
1287443F1	SDX 632V FIBER TRAY WHITE	\$19.25	0	0	0	0	0	\$0.00	365	365
1287444F1	SDX 631q FIBER TRAY	\$19.25	0	0	0	0	0	\$0.00	365	365
1287475F1	SDX 63X WHITE WALL MOUNT	\$302.50	0	0	0	0	0	\$0.00	365	365
<b>Outdoor ONT Housings</b>										
1187770G1	Outdoor ONT NID HSG SPLICE	\$35.00	0	0	0	0	0	\$0.00	1	1
1187772G1	Outdoor ONT SLACK STORAGE UNIT	\$26.00	0	0	0	0	0	\$0.00	1	1
<b>MDU Solutions</b>										
1287733F1	TA480 OUTDOOR MDU ENCLOSURE	\$919.60	0	0	0	0	0	\$0.00	365	1915
1187734G1	GPON MDU SPLITTER	\$233.75	0	0	0	0	0	\$0.00	365	1915
<b>UPS/BBU</b>										
1187731G1	ONT UPS, GPON (24 Watts)	\$82.50	0	0	0	0	0	\$0.00	1	1
1187733G1	MDU UPS, GPON (75 Watts)	\$225.00	0	0	0	0	0	\$0.00	1	1
1287406F2	Micro UPS, ALM (18 Watts) (PS18L-U7)	\$83.60	0	0	0	0	0	\$0.00	1	1
1287406F3	SDX UPS PHONIX TO 2.1MM BARREL CABLE	\$16.50	0	0	0	0	0	\$0.00	1	1
1287406F4	SDX UPS PHOENIX TO 2.1BARR Qty = 30	\$175.00	0	0	0	0	0	\$0.00	1	1
1287402G1	INDOOR ONT UPS CABLE, 6FT	\$11.55	0	0	0	0	0	\$0.00	365	1915
1187732G1	GPON UPS CABLE, 50 FT	\$60.50	0	0	0	0	0	\$0.00	365	1915
<b>SDGs 800 series</b>										
17600021F1	834-5 Ethernet RG - WiFi5- 4GE - NA	\$85.00	0	0	0	0	0	\$0.00	365	760
17600023F1	834-v6 GE Fed WiFi6 RG - 2 POTS, 4GE - NA	\$99.00	0	0	0	0	0	\$0.00	365	760
17600026F1	854-6 2.5G or SFP+ Fed WiFi6 RG - 4GE -NA	\$160.00	0	0	0	0	0	\$0.00	365	760

17600028F1	854-v6 GE/SFP+ Fed WiFi6 RG - 2 POTS, 4GE - NA	\$165.00	0	0	0	0	0	\$0.00	365	760
17600030F1	841-t6 Mesh/RG 2.5GE, 2+2+4 11ax - NA	\$125.00	0	0	0	0	0	\$0.00	365	760
17600192F1	SDG CPE-WALL MOUNT 1 - GRAY (For the 834-5, and 854-6/v6)	\$16.50	0	0	0	0	0	\$0.00	365	760
17600193F1	SDG CPE-WALL MOUNT 2 - GRAY (For the 834-v6, and 841-t6)	\$15.95	0	0	0	0	0	\$0.00	365	760
17600199F1	SDG-ST1 FIBER TRAY, WHT ( 854-6/v6)	\$15.95	0	0	0	0	0	\$0.00	365	760
<b>SDGs 8600 series - 2H 2023</b>										
17600070F1S	8612 SOS 2.5G 6DB NA,US	\$139.00	0	0	0	0	0	\$0.00	365	760
17600070F1PD	8612 PLD 2.5G 6DB NA,US	\$139.00	0	0	0	0	0	\$0.00	365	760
17600070F1PP	8612 PLP 2.5G 6DB NA,US	\$139.00	0	0	0	0	0	\$0.00	365	760
			0	0	0	0	0	\$0.00	365	760
17600071F1S	8614 SOS 2.5GSFP 6DB NA,US	\$134.00	0	0	0	0	0	\$0.00	365	760
17600071F1PD	8614 PLD 2.5GSFP 6DB NA,US	\$134.00	0	0	0	0	0	\$0.00	365	760
17600071F1PP	8614 PLP 2.5GSFP 6DB NA,US	\$134.00	0	0	0	0	0	\$0.00	365	760
			0	0	0	0	0	\$0.00	365	760
17600072F1S	8622 SOS 2.5G 6TB NA,US	\$165.00	0	0	0	0	0	\$0.00	365	760
17600072F1PD	8622 PLD 2.5G 6TB NA,US	\$165.00	0	0	0	0	0	\$0.00	365	760
17600072F1PP	8622 PLP 2.5G 6TB NA,US	\$165.00	0	0	0	0	0	\$0.00	365	760
			0	0	0	0	0	\$0.00	365	760
17600073F1S	8632 SOS 2.5G 6ETB NA,US	\$195.00	0	0	0	0	0	\$0.00	365	760
17600073F1PD	8632 PLD 2.5G 6ETB NA,US	\$195.00	0	0	0	0	0	\$0.00	365	760
17600073F1PP	8632 PLP 2.5G 6ETB NA,US	\$195.00	0	0	0	0	0	\$0.00	365	760
								\$0.00		

**\*\* Max Days Hardware Repair** - this is the maximum amount of time the device can be under standard warranty, and then hardware repair through purchase of network care.

Example, if a product has a standard warranty of 365 days, the Max Days Hardware Repair states 770 - this means that you could purchase hardware repair through Network Care for 365 days for this device.

## Adtran - Adva FSP 150 Termination Devices Bill of Materials

City of Superior - Option 1

Optional  
Termination for 1G and 10G Services

		Proposed Price	Main Site MC-LAG to Core QTY	Remote / POP 6000 Subs XGS-PON 1:64 Split QTY	Remote / POP 6000 Subs XGS-PON 1:64 Split QTY	Spares QTY	Total QTY	Total Price	Standard Warranty Days	Maximum Days Hardware Repair
<b>These FSP-150s have a local WEB GUI for Management</b>										
1078904900-01	FSP 150-GE104, with integrated AC PSU, 1x 1GbE SFP Network Port, 1x 1GbE SFP Network/Client Port, and 4x 100/1000 SFP/RJ45 Combo Client Ports, C-Temp, F150/ADV/GE104/AC, HW Rel 1.02	\$478.50	0	0	0	0	0	\$0.00	365	365
1036000631	AC Power Cable, US Plug, 2.5m, Right-Angled C13 Equipment End, CBL/AC/250/RA/US	\$9.46	0	0	0	0	0	\$0.00	365	365
1013904010	Single-Unit 19" Rack Mounting Kit for Select FSP 150 and OSA Units with 220 mm Width, F150/ADV/OT/MK-19	\$8.25	0	0	0	0	0	\$0.00	365	365
1091904796-01	GE112, GE114, GE112Pro, GE114Pro, and GE104, Software Base Key, F150/GE11X/SW/BASE/KEY	\$66.00	0	0	0	0	0	\$0.00	365	365
1091905009-01	GE104, Preinstalled SW, Release 13.7.1, GE104/SW 13.7.1/PREINST	\$0.00	0	0	0	0	0	\$0.00	365	365
<b>These FSP-150s have a local WEB GUI for Management</b>										
1078901080-01	FSP150-XG108 (H) 1RU Full-Width Layer 2 Demarcation Device with 4x 10GbE/1GbE SFP+/SFP Ports, 4x 1GbE/100M SFP Ports, and 2x Pluggable PSU Ports, I-Temp, F150/ADV/XG108/H, HW Rel 1.02	\$1,113.75	0	0	0	0	0	\$0.00	365	365
1013902002	Rack/Wall Mounting Kit for Select FSP 150 Units, with Rack Mounting Hardware for 19", 23", and ETSI Racks and Wall Mounting Hardware for 443 mm Width Units, F150/ADV/OT/MK/GE206	\$16.50	0	0	0	0	0	\$0.00	365	365
1040904090-01	FSP-150 XG-108 86W AC Power Supply, I-Temp	\$46.75	0	0	0	0	0	\$0.00	365	365
1036000633-01	AC Power Cable, US Plug, 2.5m, Straight C15 Equipment-End Connector, for CC-GE114PH 95W AC PSU, XG108 S/SH 68W AC PSU, and FSP 3000 ACC OD Series, CBL/AC/250/ST-C15/US	\$46.75	0	0	0	0	0	\$0.00	365	365
1091901106-01	FSP 150-XO106, XG108, XG108 (H), and XG108 (SH), Preinstalled SW, Release 13.7.1, XG108/SW 13.7.1/PREINST	\$0.00	0	0	0	0	0	\$0.00	365	365
1091901005-01	FSP 150-XG108, XG108 (H), and XG108 (SH), Software Base Key, F150/XG10X/SW/BASE/KEY	\$132.00	0	0	0	0	0	\$0.00	365	365
<b>1G and 10G Optics</b>										
1061701850-03	11G SFP+ IF, 1310 nm, Standard Reach, 5.000-11.400 Gbit/s, SFP+/11GU/1310S/SM/LC, HW Rel 3.01	\$51.87	0	0	0	0	0	\$0.00	365	365

1061701854-03	11G SFP+ IF, 850 nm, Intra-Office Reach, 5.000-11.400 Gbit/s, SFP+/11GU/850I/MM/LC, HW Rel 3.01	\$50.93	0	0	0	0	0	\$0.00	365	365
0061705824	SFP IF, 1310nm, Standard Reach, 100 Mbit/s-1.250 Gbit/s, SFP/HS/1310S/SM/LC, HW Rel 1.01	\$22.93	0	0	0	0	0	\$0.00	365	365
0061705844-03	SFP IF, 850nm, Intra-Office Reach, for 1G FC, 2G FC, and GigE, SFP/2G1/850I/MM/LC, HW Rel 3.01	\$36.83	0	0	0	0	0	\$0.00	365	365
1061705850-02	SFP IF, 1310 nm, Standard Reach, Gigabit Ethernet (FSP 3000/FSP150) and Fast Ethernet (FSP 150 only), with Industrial Temperature Range, SFP/GBE/1310S/SM/LC/TIN, HW Rel 2.01	\$22.93	0	0	0	0	0	\$0.00	365	365
1061705854-02	SFP IF, 850 nm, Intra-Office Reach, Gigabit Ethernet (FSP 3000/FSP150) and Fast Ethernet (FSP 150 only), with Industrial Temperature Range, SFP/GBE/850I/MM/LC/TIN, HW Rel 2.01	\$29.26	0	0	0	0	0	\$0.00	365	365
									\$0.00	



## Training Options

		Proposed Price	QTY	Total QTY	Total Price
<b>SDX 6000 OLT Training</b>					
1600CSYS6025C	SDX OLT SWITCH COURSE (up to 12 students)	\$6,600.00	0	0	\$0.00
1600CSYS6025E	SDX OLT ENROLLMENT per person	\$900.00	0	0	\$0.00
<b>Mosaic Cloud Platform (MCP) Training</b>					
1600CSYS6015C	MOSAIC CLOUD PLATFORM COURSE (up to 12 students)	\$3,500.00	0	0	\$0.00
1600CSYS6015E	MOSAIC CLOUD PLATFORM ENROLLMENT per person	\$550.00	0	0	\$0.00
<b>Mosaic One (M1) Training</b>					
1600CSYS1000V	MOSAIC DEVICE MGR CSR SKILLS	\$250.00	0	0	\$0.00
1600CSYS1000VC	MOSAIC DEVICE MGR CSR SKILLS CLASS (Private Course)	\$1,000.00	0	0	\$0.00
1600CSYS1010V	MOSAIC DEVICE MGR ADMIN	\$200.00	0	0	\$0.00
1600CSYS1010VC	MOSAIC DEVICE MGR ADMIN CLASS (Private Course)	\$250.00	0	0	\$0.00
1600CSYS1020V	MOSAIC HOME ANALYTICS	\$250.00	0	0	\$0.00
1600CSYS1020VC	MOSAIC HOME ANALYTICS CLASS (Private Course)	\$1,000.00	0	0	\$0.00
					\$0.00

Other customized course options are available.

Contact Adtran Training Team to discuss.

## Product specifications

Feature	8310-64	8310-32	8305-20	8210-54	8205-54	8205-54M	8120-14
<b>Link interfaces</b>	4x100GbE QSFP-DD/28 6x100GbE QSFP28	32x100GbE QSFP28	20x100GbE QSFP28	6x100GbE QSFP28 48x10GbE SFP+	2x100GbE QSFP-DD/28 4x100GbE QSFP28 48x10GbE SFP+	2x100GbE QSFP-DD/28 4x100GbE QSFP28 48x10GbE SFP+	4x10GbE SFP+ 10x1GbE SFP
<b>Each port supports</b>	QSFP: 1x100GbE 1x40GbE 4x25GbE (breakout cables) 4x10GbE (breakout cables)	QSFP: 1x100GbE 1x40GbE 4x25GbE (breakout cables) 4x10GbE (breakout cables)	QSFP: 1x100GbE 1x40GbE 4x25GbE (breakout cables) 4x10GbE (breakout cables)	QSFP: 1x100GbE 1x40GbE 4x25GbE (breakout cables) 4x10GbE (breakout cables)  SFP+: 1x10GbE 1x1GbE	QSFP: 1x100GbE 1x40GbE 4x25GbE (breakout cables) 4x10GbE (breakout cables)  SFP+: 1x10GbE 1x1GbE	QSFP: 1x100GbE 1x40GbE 4x25GbE (breakout cables) 4x10GbE (breakout cables)  SFP+: 1x10GbE 1x1GbE	SFP+: 1x10GbE 1x1GbE
<b>Switch capacity</b>	6.4 Tbps	3.2 Tbps	3.2 Tbps	880 Gbit/s	880 Gbit/s	880 Gbit/s	140 Gbps
<b>Jumbo frames MTU</b>	9216 Bytes	9216 Bytes	9216 Bytes	9216 Bytes	9216 Bytes	9216 Bytes	9216 Bytes
<b>MAC addresses</b>	136K	136K	136K	750K	750K	750K	64K
<b>Rack units</b>	2RU	1RU	1RU	1RU	1.5RU	1.5RU	1RU
<b>Mounting brackets</b>	19, 21, 23-in	19, 21, 23-in	19, 21, 23-in	19, 21, 23-in	19, 21, 23-in	19, 21, 23-in	19, 21, 23-in
<b>Airflow options</b>	F2B	F2B	S2S, F2B, F2T	F2B	S2S	S2S	S2S
<b>Dimensions (DxWxH)</b>	550 x 438 x 89 mm	511 x 440 x 43 mm	235 x 386 x 43.7 mm	548 x 440 x 44 mm	230 x 387 x 66 mm	230 x 387 x 66 mm	230 x 387 x 44 mm
<b>Weight</b>	23 lbs/10 kg	24 lbs/10.9 kg	8.8 lbs/4 kg	21.4 lbs/9.7 kg	23 lbs/10 kg	23 lbs/10 kg	8.8 lbs/4 kg
<b>Powering options</b>	Hot-swappable AC or DC	Hot-swappable AC or DC	-48VDC redundant feed	Hot-swappable AC or DC	-48VDC redundant feed	-48VDC redundant feed	Hot-swappable AC or DC
<b>Typical power consumption w/o optics</b>	375 W	240 W	130 W	270 W	100 W	135 W	50 W
<b>Typical power consumption with optics*</b>	735 W	280 W	206 W	330 W	220 W	270 W	60 W
<b>Max power consumption w/o optics</b>	500 W	543 W	170 W	420 W	160 W	200 W	100 W
<b>Temperature range</b>	0 to 45°C	0 to 45°C	0 to 50°C	0 to 40°C	-40 to 70°C	0 to 50°C	-25 to 70°C
<b>Relative humidity</b>	up to 95% non- condensing	up to 95% non- condensing	up to 95% non- condensing	up to 95% non- condensing	up to 95% non- condensing	up to 95% non- condensing	up to 95% non- condensing

\* Please note, the typical power consumption with optics is dependent on the equipped optical modules.

## SDX 8000 SERIES

### Portfolio Summary

#### SDX 8120-14

- 10-Port 1GE Carrier Ethernet Switch
- 10x1GE, 4x10GE Uplinks
- Advanced CE Features with H-QoS
- Side-to-side Airflow
- Edge Router and P2P Ethernet Access Function
- Fits in 300mm ETSI Rack
- Temperature Hardened



#### SDX 8205-54

- 48-Port 10GE Carrier Ethernet Switch
- 48x10GE, 6x100GE Uplinks
- Advanced CE Features with H-QoS
- Side-to-side Airflow
- Remote OLT and Carrier Ethernet Services Aggregation
- Fits in 300mm ETSI Rack
- Temperature Hardened



#### SDX 8210-54

- 48-Port 10GE Carrier Ethernet Switch
- 48x10GE, 6x100GE Uplinks
- Advanced CE Features with H-QoS
- Side-to-side Airflow
- Remote OLT and Carrier Ethernet Services Aggregation



#### SDX 8305-20

- 20-Port 100GE Switch
- 20x100GE Uplinks
- Side-to-side and Front-to-back Airflow Options
- Front-to-top
- Fits in 300mm ETSI Rack



#### SDX 8310-32

- 32-Port 100GE Switch
- 32x100GE Uplinks
- High Capacity L2/L3 Forwarding
- Front-to-back Airflow
- High-density OLT Aggregation



#### SDX 8310-64

- 64-Port 100GE Switch
- 64x100GE Uplinks
- High Capacity L2/L3 Forwarding
- Front-to-back Airflow
- High-density OLT Aggregation



## Product Specifications

Feature	6330-48	6320-16	6020-48	6010-16	6312-4
10G Combo PON Supported	•	•			•
XGS-PON Interfaces	48	16			4
GPON Interfaces	48	16	48	16	4
Uplink Interfaces	2x200GE QSFP-DD 2x100GE QSFP28 2x10/25GE SFP28	4x100GE QSFP28 4x10GE SFP+	4x100GE QSFP28 4x10GE SFP+	2x40GE QSFP+ 4x10GE SFP+	4x10GE SFP+
Jumbo Frames MTU	9216 Bytes	9216 Bytes	9216 Bytes	9216 Bytes	9216 Bytes
MAC Addresses	256K	256K	256K	256K	256K
Multicast Bundles	50	50	50	50	50
Multicast Streams	32K	32K	32K	32K	32K
Rack Units	2.5RU	1.5RU	2RU	1RU	Environmentally Sealed
Mounting Brackets	19, 21, 23-in	19, 21, 23-in	19, 21, 23-in	19, 21, 23-in	
Airflow Options	S2S	S2S	S2S	S2S, F2B	Fanless Conductive Cooling
Baffle Kits Available	F2B, F2T, B2T	F2B, F2T, B2T			
Dimensions (DxWxH)	225 x 387 x 110 mm	225 x 387 x 66 mm	235 x 437 x 87 mm	S2S: 236 x 437 x 44 mm F2B: 336 x 437 x 44 mm	243 x 515 x 280 mm
Weight	14.2 lbs/6.4 kg	10.14 lbs/4.6 kg	13 lbs/5.9 kg	8.8 lbs/4 kg	35 lbs/16 kg
Powering Options	-48VDC Redundant Feed	-48VDC Redundant Feed	-48VDC Redundant Feed	-48VDC Redundant Feed	AC/DC, Span or CATV
Typ Power Consumption Without Optics	280 W	220 W	220 W	95 W	70 W
Max Power Consumption Without Optics	435 W	280 W	280 W	141 W	80 W
Temperature Range	-40 to 65°C	-40 to 70°C	-40 to 65°C	S2S: -40 to 65°C F2B: 0 to 50°C	-40 to 65°C
Relative Humidity	up to 95% non-condensing	up to 95% non-condensing	up to 95% non-condensing	up to 95% non-condensing	up to 95% non-condensing

## SDX 6000 SERIES

### Portfolio Summary

#### SDX 6330-48

48-Port Hardened 10G Combo PON OLT

- 48 (96)\* 10G Combo PON Ports
- 2x200GE, 2x100GE, and 2x10/25GE Uplinks
- Side-to-Side or Front-to-Back Airflow Options
- Hardened for Remote Cabinet Deployment



#### SDX 6020-48

48-Port GPON OLT

- 48 GPON Ports
- 4x100GE and 4x10GE Uplinks
- Side-to-Side Airflow
- Lower Power and Cost Per Port for High-Density Sites



#### SDX 6010-16

16-Port GPON OLT

- 16 GPON Ports
- 2x40GE and 4x10GE Uplinks
- Side-to-Side or Front-to-Back Airflow Variants
- Side-to-Side Variant Hardened for Remote Cabinet Deployment



#### SDX 6320-16

16-Port Hardened 10G Combo PON OLT

- 16 (32)\* 10G Combo PON Ports
- 4x100GE and 4x10GE Uplinks
- Side-to-Side or Front-to-Back Airflow Options
- Hardened for Remote Cabinet Deployment



#### SDX 6312-4

4-Port Sealed 10G Combo PON OLT

- 4 (8)\* 10G Combo PON Ports
- 4x10GE Uplinks
- Environmentally Sealed Unit (IP68)
- Fanless Conductive Cooling
- Stand, Pole, Wall, or Pedestal Mount Options



# Adtran SDX PON OLT and Aggregation Services Quote

City of Superior - Option 1

9/29/2023

PN	Short Description	Qty	Ext Price
1901-MCPSWINST01	MCP BASE SOFTWARE INSTALL	1	\$700.52
1901-MCPPLUGIN01	MCP PLUG IN ADDL	2	\$156.04
1901-MCPPROFAD01	MCP PROFILES ADDL	1	\$156.04
1901-MCPEQDISC01	MCP EQUIP DISCOVERY	6	\$512.94
1901NTWKENGBAS01	BROADBAND ENGINEERING DEPLOYMENT	136	\$19,537.76
1901RSPNICOSS001	RSP NI CO SITE SURVEY	1	\$977.34
1901RSPNIIRTSS001	RSP NI RT SITE SURVEY	2	\$1,396.20
1901RSPNITA5KEN1	RSP NI CO TA5K / SDX ENG	3	\$4,186.26
1901-ENGCLSOUT01	Engineering Closeout	3	\$416.52
1901RSPNIINST003	CO Shelf Add (TA5K or SDX) Installation	1	\$5,175.30
1901RSPNIINST004	CO Shelf Add (TA5K or SDX) (Ea. Add'l) Installation	1	\$4,491.24
1901RSPNIINST005	RT Shelf Add (TA5K or SDX ) Installation	2	\$6,186.96
1901RSPNIINST006	RT Shelf Add (TA5K or SDX) (Ea. Add'l) Installation	2	\$4,818.84
1901-ENGMOPISP01	MOP - ISP DETAILED Installation	3	\$430.98
1901-ENGMOPSWU01	MOP Creation - Software Install and TTU Provisioning	5	\$1,564.55
1901NATLDEPLMT48	Installation required MATL	2720	\$2,883.20
1901-INSTMobil01	Installation Mobilization (applied per \$100 increment)	105	\$10,500.00
		Total	\$64,090.69

Services Quote for full Turnkey Solution for 3 Sites and associated material associated with this BOM  
 Quote will remain the same for Option 1 and Option 2 for Turnkey Solution for 3 sites.  
 See Associated Pro Services Scope of Work for details

Adtran

# Welcome to Mosaic One

City of Superior

Powered by Adtran

10/3/2023



# Unified View, Simplified Management, Revenue-realizing Solution

Mosaic One streamlines customer care, network operations, and marketing campaigns to safeguard customer loyalty and increase your bottom line through **AI-driven insights** and **actionable intelligence**.





# It's not enough just to offer broadband services



Is your team operating efficiently and effectively?



Are your costs increasing your total deployment investment?



Would your customers refer you to neighbors and friends?



Is your market vulnerable to competitors?

# Introducing Mosaic One

Mosaic One is a cloud-based Software as a Service (SaaS) that aggregates AI-driven insights from network management and service orchestration applications pulling data from access network platforms and in-home devices.

The result equips service providers with a unified view of their network health and customer experience, with three distinct portals for the unique facets of business: **Care, Operate and Promote.**



# Mosaic One and the converged broadband edge

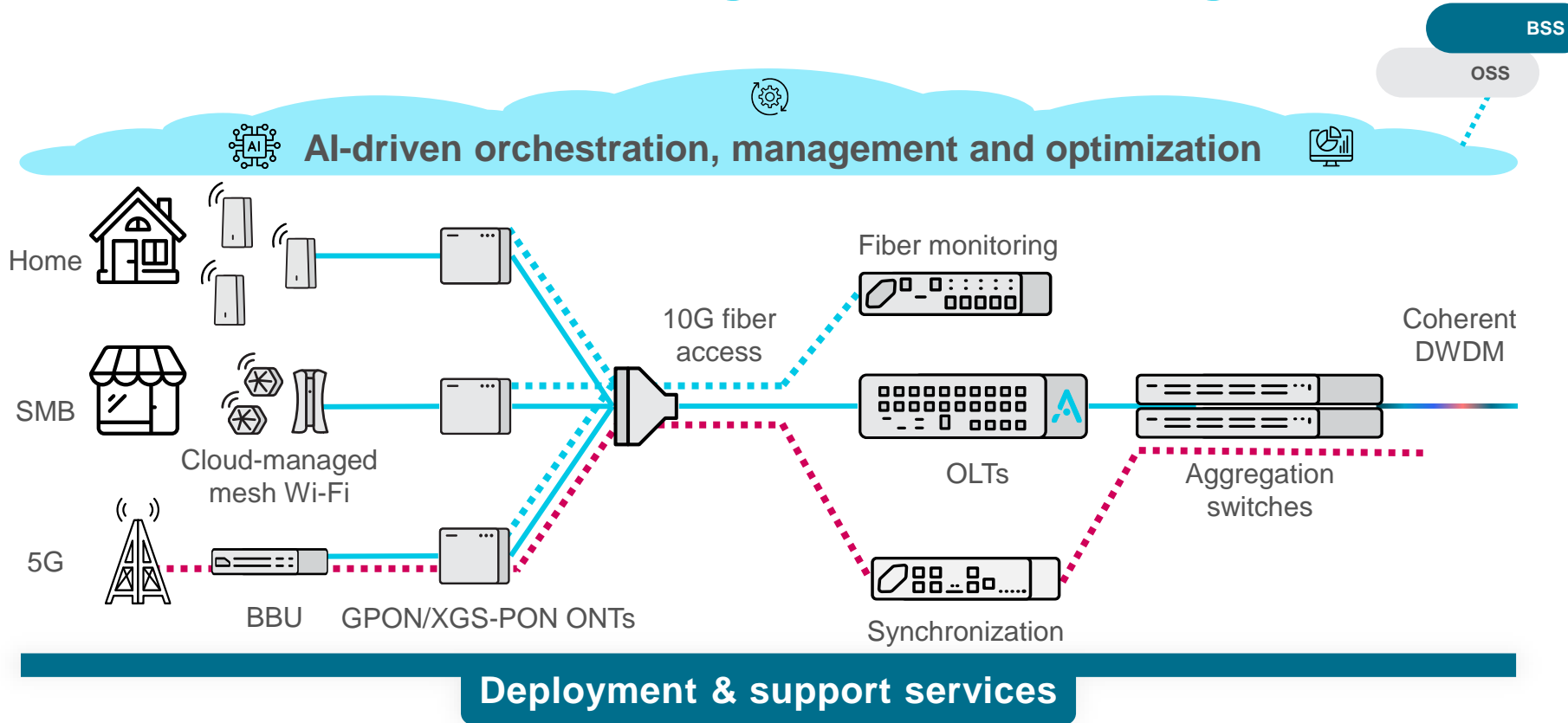

## WHY MOSAIC ONE

# How Mosaic One works

### Mosaic One AI data steward:

**Aggregates Data Points and Insights** from every point in your business.

**Structures and Warehouses** data for simplified access.

**Filters and Categorizes** via queries using **Care, Operate,** and **Promote** portals.

**Provides Open Direct access** to Your data using standard APIs, for your own custom portal creation.

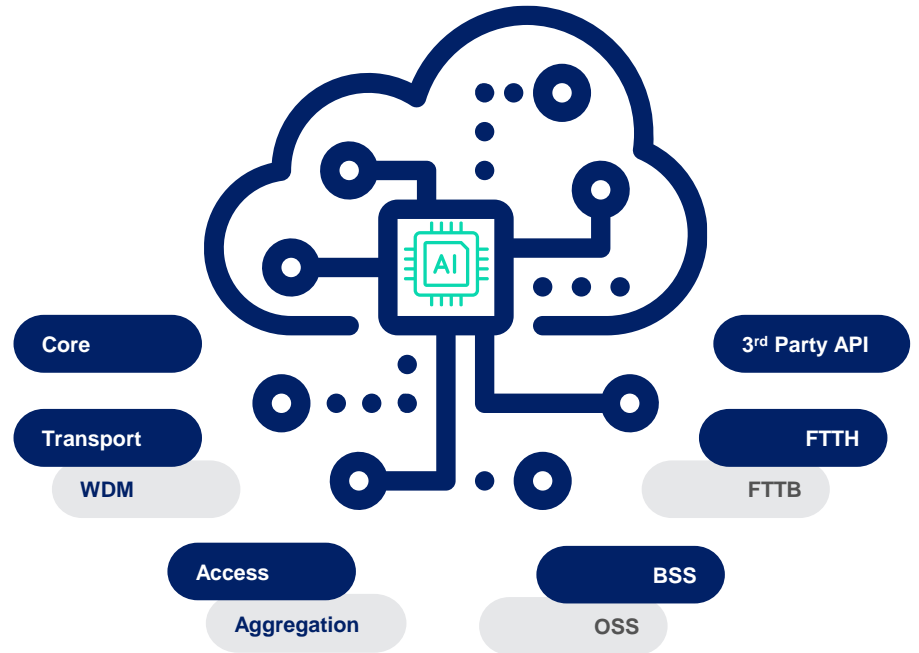

# One solution, three areas of focus



## Care

for Customer Success

View and resolve customer issues quickly from a single-view reducing costly escalations



## Operate

for Network Engineers

Monitor preemptive network insights to allow issue resolution before service interruption



## Promote

for Marketers

Assess user behavior and subscriber insights to simplify and maximize marketing campaigns

WHY MOSAIC ONE

# Mosaic One benefits



**20%**

Higher monthly  
ARPU



**36pts**

Increase in NPS

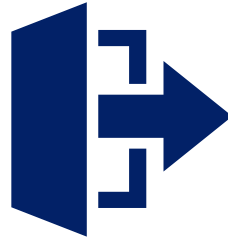

**25%**

Lower churn



**50%**

Reduced truck  
rolls



**50%**

Fewer support  
calls

# Care for customer service

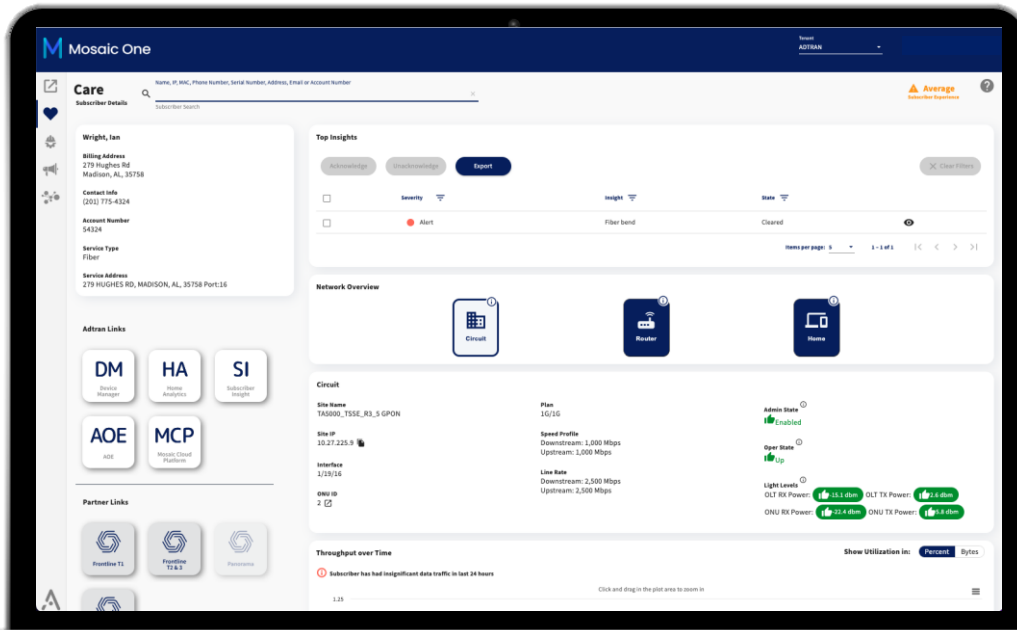

## Safeguard Customer Loyalty with Great Customer Experiences

Troubleshoot a subscriber's entire connection with **a simple search**

Visualize quickly, by subscriber, **current and recent device alarms** for all devices

**Understand customer experience** with at-a-glance indicators, light level read-outs, and throughput utilization

**Utilize actionable intelligence** via AI-driven insights to identify issues and recommend resolutions – without escalation or truck rolls.

# Residential Wi-Fi for customer experience

**Intellifi:** complete connected home solution that is purpose-built for operators to deliver the Wi-Fi subscribers want:

**Intelligent Wi-Fi that just works!** For all users, everywhere

**Flexible and powerful SaaS software** to deliver a differentiated subscriber experience

**Higher value and revenue-generating tools** to unlock the in-home opportunity

**Empower CSRs to deliver proactive care** with Mosaic Subscriber Solutions

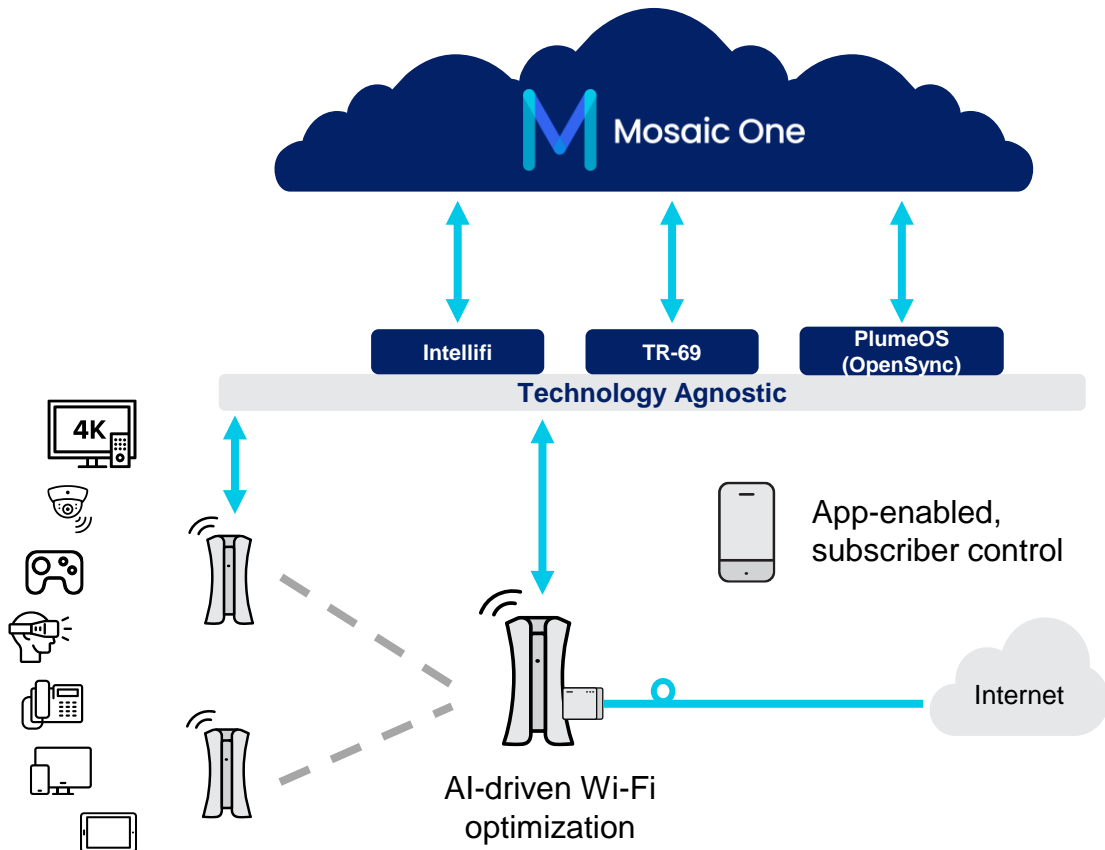

# Operate for network monitoring

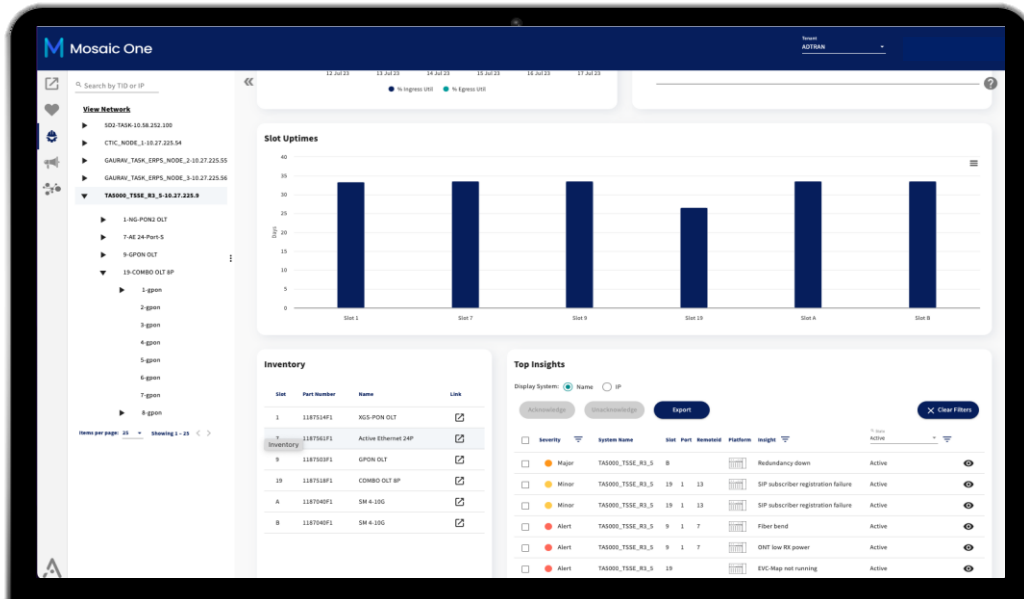

## Maintain a Resilient Network

Scan your network to identify insights from bad light levels on a fiber to high PON, backplane, or CPU usage – and everything in between – and quickly assess risk severity.

Identify the primary cause of the insight and view recommendations for resolution quickly from AI-driven insights.

Reduce truck rolls with actionable intelligence on each network element.

Increase subscriber uptime and network availability by proactively correcting issues.

# Promote for sales and marketing

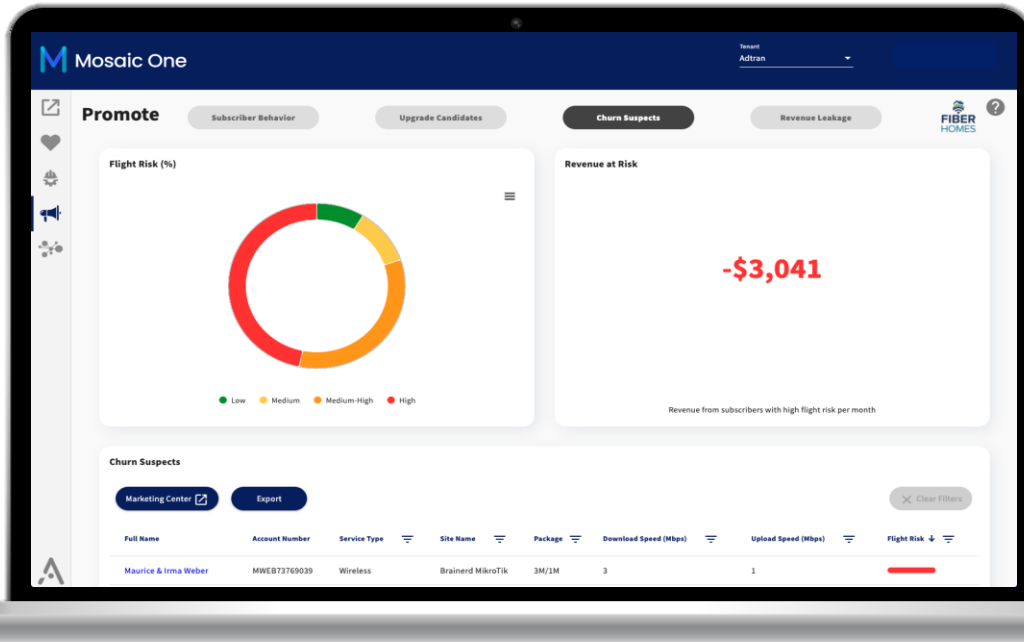

**Elevate your Customer Outreach through AI-Driven Insights**

**Increase service take-rate** through promotion targeting.

**Analyze subscriber behavior** to segment audiences and build highly targeted campaigns.

**Increase potential revenue** by preemptively identifying upgrade and churn candidates.

**Craft distinctive campaigns** with the help of the **Mosaic Marketing Center** – a library of resources with ready-to-brand content included with Mosaic One Promote



# Marketing beyond the software



**Unlock your market potential with the industry's best sales and marketing tools included with Mosaic One Promote**

**Exclusive access** to Mosaic Marketing Center and Fiber Homes Pro with the Mosaic One suite

**Act on analytics** with ready-to-brand campaigns built by broadband marketers

**Rise above competitor noise** with localized marketing strategies on-demand

**Grow brand equity** by identifying key market growth opportunities

**Capitalize on real estate market** opportunities to reach new subscribers, partner with agents, and drive community growth

## MOSAIC ONE PARTNERSHIPS

# Marketing platforms for growth

	Level 1	Level 2	Level 3
Full access to Mosaic Marketing Center	✓	✓	✓
Self-customizable static marketing materials	✓	✓	✓
Update font, color, text, logo	✓	✓	✓
Update content with your photography	✓	✓	✓
Upload your own photography	✓	✓	✓
Campaign suggestions from Promote data	✓	✓	✓
Customizable video marketing materials		✓	✓
Social media best practices guide		✓	✓
Promotion and pricing best practices guide		✓	✓
Marketing consulting services			6 hours per quarter
Local stock photo video services & shot list			Once per year
1 Day			INCLUDED
2 Day			\$500
Travel Expenses			Based on travel
Raw Footage			INCLUDED

“Mosaic Marketing Center helps me convert incredible footage they produced into beautiful, localized marketing assets in just a few clicks. **There truly is power in partnership and now that we are working with Adtran and DxTEL we are accomplishing more than we ever have.**”

**Alexis Westbrooks**  
 Director of Marketing  
 Douglas Fast Net



# Marketing beyond the software



## Capture the value of the gaming community with Fiber Gaming Network from Mosaic One

**Increase average revenue per user** with a gaming platform, increased packages, and advanced gateways, gaining value from the untapped gaming community within the subscriber base.

**Build quality relationships with the local schools** with resources to create, manage, and run esports leagues.

**Connect local esports gamers and schools with college recruiters** through an exclusive Discord channel and college directory – with scholarship listings.

**Improve targeted campaigns with advanced analytics on gamers** – both current customers and prospects – combined with ready-to-brand content in the Mosaic Marketing Center.

# Software as a Service, at your service



## Mosaic One Onboarding

- With your team from contract signing through integration
- Guide customers through integration and installation of all Mosaic One Portals and Applications
- Orientation and training



## Customer Success Manager (CSM)

- CSM Goal is ensure Successful Software adoption and value proposition customer purchased is achieved.
- Feedback to Adtran Product Management and Engineering teams for continuous improvement.
- Average tenure of team is 15+ years with Adtran



## Technical Assistant Center

- Software Support
- Hardware Support
- Staffed by Huntsville and remote US-based Employees 24/7/365

# One annual price, one annual invoice



**Keep your focus on what matters, not confusing invoice terms**

**Plan your budget accurately and efficiently** with clear pricing, three-year projections, and once-a-year invoicing.

**Simplify accounting and billing** by combining any existing contracts or underlying platforms and partnerships into one proposal.

**Pay for what your network design needs** with custom quotes built with attention to your unique details.

# Mosaic One Proposal

Mosaic One License Schedule			
SERVICES	YEAR 1	YEAR 2	YEAR 3
MOSAIC ONE	2,000	5,000	8,000
MOSAIC CLOUD PLATFORM OLT	2	3	4
MOSAIC CLOUD PLATFORM ONT	200	300	400

Mosaic One Subscription Fee Schedule				
	YEAR 1	YEAR 2	YEAR 3	TOTAL
SUBSCRIPTION FEE	\$72,066	\$148,181	\$217,201	\$437,448

Mosaic True-Up Fee	
SERVICE	PER LICENSE FEE
MOSAIC ONE	\$28
MCP OLT	\$200
MCP ONT	\$2

# Mosaic One Proposal

## Included In Proposal:

- |   |   |
|---|---|
| 1. One-time Onboarding and Training       | 11. Intellifi                                     |
| 2. Mosaic One Frontend and Single Sign-On | 12. Mosaic One Enhanced Software Support          |
| 3. Mosaic One AOE                         | 13. Mosaic One Enhanced Hardware Support          |
| 4. Mosaic Cloud Platform OLT              | 14. Speed Test Server Access                      |
| 5. Mosaic Cloud Platform ONT              | 15. Network Performance Testing - (1) Small       |
| 6. Mosaic One Operate                     | 16. Mosaic One Fiber Homes (up to 250k addresses) |
| 7. Mosaic One Promote                     | 17. Mosaic One Marketing Center T2                |
| 8. Mosaic One Care                        |   |
| 9. Mosaic One Device Manager              |   |
| 10. Mosaic One Home Analytics             |   |

## Proposal Notes:

1. License true-up at the end of each contract year.
2. At time of true-up, if the contracted license quantities are exceeded, an overage charge will apply. The charge for the additional licenses is a one-time annual per-license charge shown in the true-up table below. 3. Adtran includes software maintenance, 24x7x365 SLA based access to Technical Support, and repair and return for hardware as part of Mosaic One as quoted in this response. In addition, Adtran offers next business day replacement (NBD) options. NBD is applicable to all serialized hardware other than ONTs, Residential Gateways, and PON Optics as these are typically spared by the service provider. NBD is priced at \$4200 for year 1 and at 3.5% of price of the installed base (IB) each year beginning in year 2. The installed base is calculated based on the cumulative spend on serialized hardware and embedded software other than ONTs, Residential Gateways, and PON Optics at the beginning of each year of the contract period beginning at year 2. NBD is also available on ONTs, Residential Gateways, and PON Optics.
3. M1 Contract includes a supporting ADTRAN Customer Success Manager.

**Thank You**

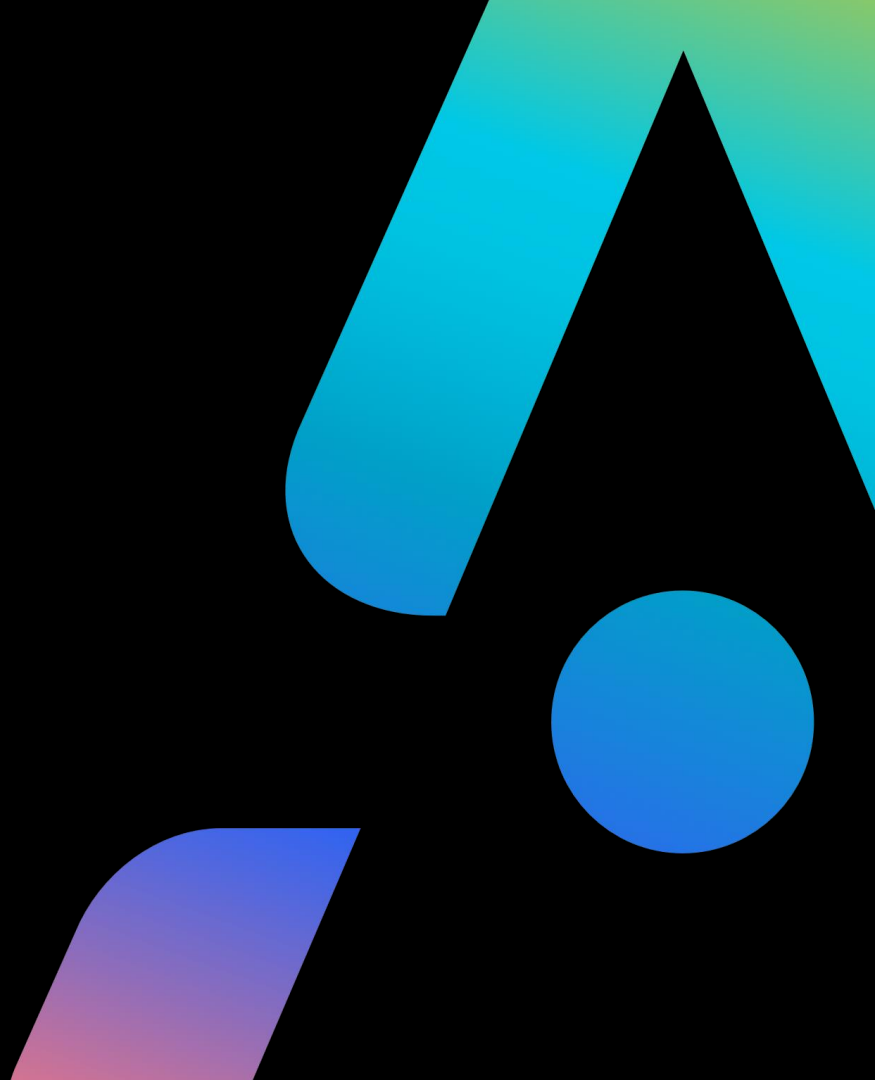





# Engineering, Installation & Commissioning Service for SDX OLT equipment

## City of Superior, WI RFI

Adtran Response No. 1236550



# **ADTRAN SERVICES SCOPE OF WORK**

*Project: SDX Network Deployment for City of Superior, WI*

## **TABLE OF CONTENTS**

1. Project Overview
2. ADTRAN Responsibilities
  - 2.1. Project management
  - 2.2. Detailed Design
    - 2.2.1. High Level Design
    - 2.2.2. Low Level Design
    - 2.2.3. Site Survey (On-Site)
    - 2.2.4. Site Design
  - 2.3. MCP Installation
  - 2.4. SDX OLT and Agg shelf Installation and Test & Turn Up
    - 2.4.1. SDX OLT and Agg shelf Installation
    - 2.4.2. Test and Turn Up
    - 2.4.3. Test and Verification Process
  - 2.5. Completion Process
  - 2.6. ADTRAN Contacts
3. Customer Responsibilities
4. Change Order Process
5. Assumptions
6. Exclusions
7. Additional Terms and Conditions

## **1 – Project Overview**

- Adtran in partnership with the City of Superior, WI will Engineer, deliver to site, install, power-up, configure, commission and test Adtran’s SDX-based OLT equipment and software in the 3 proposed customer Pop locations. The work described in this SoW will only apply to the SDX equipment and associated material quoted in the specific bid response.

## **2 – ADTRAN Responsibilities**

Adtran Professional Services will perform the following tasks:

### **2.1 Project Management**

- ADTRAN Professional Services will assign a Project Manager (PM) upon receipt of the customer Purchase Order for the services described in the SoW. The Project Manager responsibilities include the following:
  - Understand, review, and analyze the project requirements by providing overall project management through engineering, installation, configuration, test/turnup, and acceptance of that SoW.
  - Coordinate and manage those products and services specified in the Statement of Work, including schedule, financial and quality objectives, as mutually agreed with the Customer.
  - Act as a single point-of-contact for the customer and Adtran Project Team by providing overall project direction and effective resource management, scheduling, and communication.
  - Schedule initial project kick off meeting to confirm scope and coordinate initial logistics.
  - Respond promptly to all inquiries and/or escalations regarding project.
  - Provide regular project communication and coordinate required meetings.
  - Manage and coordinate any change orders.
  - Provide deliverable documentation as described in this SoW.

### **2.2 Detailed Design**

#### **2.2.1 High Level Design**

- To capture all design requirements, the Adtran Sales Engineer will work with the customer to establish the overall Network to be built.
  - Topology view – This will be used to provide the high-level topology of the network including transport & access components.
  - Chassis view – This would be used to capture either the transport or access chassis views to provide an overview of components in the chassis.
  - The following items are expected to be included as a minimum for all HLDs:
    - Chassis level overview of equipment being proposed

- All CPE and/or ancillary components being provided
- Software representation (local or hosted)
- Network Service dependencies (OSS/BSS, Monitoring, DHCP, etc.)
- Interface types and speeds between all equipment elements (Rings, LAGs, 10G,40G,100G)
- Clear demarcation of network elements and responsibility (i.e. aggregation switch/router or 3rd party GW)
- Services expectations (ex IPv4/IPv6, Data-Tagged/untagged, VoIP-SIP/MGCP, IPTV)

### **2.2.2 Low Level Design**

- The Adtran Broadband Engineer will provide a low-level design (LLD) for the Access Network to be used as a record document of all logical details of the build. The LLD will provide a detailed explanation of physical and logical behaviors at every segment of the Adtran Access Network proposal. These are multi page documents meant to aid in the installation and operation of the solution and the services carried over it, as well as a detailed record for the customer of all information used to turn up their network.
  - The following items are expected to be included as a minimum for all LLDs:
    - Definition of each Access network physical connection (uplink, downlink, power, management, monitoring) to include expected transmit/receive values.
    - All MCP (Mosaic Cloud Platform) configurations
    - Any/all VLANs being carried of each link
    - Any VLAN translations at each interface
    - All management connections and configurations (in & out band)
    - Profile definitions for each service
    - Individual software instances and resource requirements
    - All OLT Configurations pushed during the Turn Up and provisioning process
    - API definition(s)

### **2.2.3 Site Survey**

- Adtran will provide an Engineer On-Site to conduct a site survey at each of the 3 proposed sites for the City of Superior, WI network build.
  - The site survey shall capture details pertinent to engineering the implementation of an ADTRAN SDX shelf into an existing relay rack or cabinet. This site survey will capture all site-specific details required to design the site including space, power, heat, and cable management. These details will be captured on an ADTRAN site survey form and will be provided to the customer via final engineering documents for future use.

### **2.2.4 Site Engineering**

- Adtran Design Engineering will take all documentation from associated equipment BOM's and information from the Site Survey and build an EDP (Engineering Design Package) as the Physical

Design of the City of Superior, WI network. An EDP will be completed for each of the 3 proposed site locations.

- Site Engineering ensures all installation requirements of a project are accounted for before the installation of an ADTRAN SDX shelf, the installer has all required documentation required to successfully complete install, and the customer has a detailed record of what was deployed into their network. During the Site Engineering phase of a project, ADTRAN will produce a detailed engineering design package to include the following:
  - Bill of materials, both ADTRAN and 3rd party, required to complete the installation.
  - Rack drawing of the existing rack and ADTRAN SDX shelf.
  - Network diagram showing the ADTRAN SDX uplink and distribution connections.
  - Detailed installation instructions and documentation.
  - Cable running list detailing all power and fiber runs required to deploy the shelf.

## 2.3 MCP Installation

The Adtran Broadband Engineer will perform the following to install MCP into the City of Superior, WI production network.

- **MCP Installation**
  - Establish server using ADTRAN recommended requirements
    - Partition hard drives and load CentOS7
  - Create detailed MOP for installation procedures with all detailed customer required information for the correct MCP plugins and any custom profiles needing to be built
  - MCP Core Application
    - Upload and apply base files to server
  - SDX Plugins
    - Load plugin for SDX OLT Tools Framework
      - Plugins required to support hardware deployment
  - Load SDX example Profiles
    - Service profiles for Data, Video and Voice
    - Service Vector profiles to enable speed profiles and auto builders

## 2.4 SDX OLT Installation and Test & Turn Up

### 2.4.1 SDX OLT and Agg shelf Installation

The Adtran technician will follow the below steps that will be applicable to all 3 of the proposed locations for the City of Superior, WI, network build.

- Provide the specific tools, hardware, and software required to perform this service

- Move specific equipment to correct location within site, unpack and verify delivery against shipping list and dispose of all packaging
- Create detailed MOP of installation procedures and power cuts to new equipment for each site
- Installation of active equipment to rack, slotting of SFPs
- Running, cleaning, and testing of all intra and inter rack optical cabling from SDX equipment to termination points utilizing existing cable management infrastructure.
- Power up checks including verification of visual alarm statuses
- Complete all power, fiber, and rack labeling in accordance with the customer specifications.

#### **2.4.2 Test & Turn-up**

An Adtran Broadband Engineer will complete the following work On-Site at all 3 proposed locations. Detailed MOPS will be established for each site with pertinent assignments and configurations for all shelves within in each site.

##### **Site 1 / Main PoP... (2) SDX-8250 series shelves**

- Test and turn up the (2) SDX-8205 series shelves into Customer's network on-boarding through MCP
  - Upgrade to latest software release if required
  - Build customer service profiles (Data, video, voice)
  - Build service vector profiles (speed profiles and auto builders)
  - Run Management profile script with information provided by customer
    - Management IP – In band/Out of band
    - Management VLAN
    - Management Gateway
    - Management Subnet
    - Uplink Configuration 10G or 100G/200G/LAG
    - Set Configurations to establish ring design
    - Set Clock parameter
  - Onboard SDX-8205 series shelf into MCP

##### **Site 2 / Remote PoP 1... (2) SDX-6330 series shelves**

- Test and turn up the (2) SDX-6330 series shelves into the City of Superior, WI network on-boarding through MCP
  - Upgrade to latest software release if required
  - Build customer service profiles (Data, video, voice)
  - Build service vector profiles (speed profiles and auto builders)
  - Run Management profile script with information provided by customer
    - Management IP – In band/Out of band
    - Management VLAN
    - Management Gateway

- Management Subnet
- Uplink Configuration 10G or 100G/200G/LAG
- Establish configuration of shelf into proposed ring
- Set Clock parameter
- Onboard SDX-6330 series shelves into MCP

### **Site 3 / Remote PoP 2... (2) SDX-6330 series shelves**

- Test and turn up the (2) SDX-6330 series shelves into the City of Superior, WI network on-boarding through MCP
  - Upgrade to latest software release if required
  - Build customer service profiles (Data, video, voice)
  - Build service vector profiles (speed profiles and auto builders)
  - Run Management profile script with information provided by customer
    - Management IP – In band/Out of band
    - Management VLAN
    - Management Gateway
    - Management Subnet
    - Uplink Configuration 10G or 100G/200G/LAG
    - Establish configuration of shelf into proposed ring
    - Set Clock parameter
  - Onboard SDX-6330 series shelves into MCP

### **2.4.3 Test and Verification Process**

The Adtran Broadband Engineer will follow Test and Verification functions On-Site at all 3 proposed locations

- Test 2 chosen ONT's per SDX-6330 series shelf for backhaul connectivity
- Onboard ONT into MCP
- Create service in MCP
- Perform speed testing
- With assistance from City of Superior, WI Adtran Broadband Engineer will perform any required failover testing on Core uplinks.
- Upon further discussion on requirements from City of Superior, WI a speed test server shall be deployed on VM instance they have setup.
  - Build detailed MOP around installing and testing procedures for chosen speed test server

### **2.5 Completion Process**

- **Acceptance**
  - Completion of Quality Checks
  - Review the results of test activity with the customer-assigned representative

- Obtain sign-off from customer-assigned representative confirming satisfactory completion of each test activity
- **Applicable Documents**
  - The attachments (“Attachments”) listed in this section shall become an integral part of this SoW as the Documentation Deliverables to be handed off to the customer at the completion of the project.
    - High Level Design
    - Low Level Design
    - Engineering Design Package (EDP)
  - Any As-Builts required for the LLD and EDP will be completed to reflect any changes from the original design, due to changes in field conditions or connectivity in the field.

## 2.6 ADTRAN Contacts

ADTRAN contacts to support this SOW are as follows. Note that the Design and Broadband engineer’s name or partner contact information will be provided by the PM once the order is received.

### ADTRAN Primary Contact

NAME	TITLE	EMAIL	PHONE
Angela Peratta	Project Manager, Professional Services	<a href="mailto:angela.peratta@adtran.com">angela.peratta@adtran.com</a>	256-963-7037 (O)
Lou Windsor	Manager, Professional Services	<a href="mailto:lou.windsor@adtran.com">lou.windsor@adtran.com</a>	256-963-4511 (O)
Sean Stacy	Engineering Manager, Broadband Deployment Engineering	<a href="mailto:Sean.stacy@adtran.com">Sean.stacy@adtran.com</a>	256-963-5890 (O)

## 3 - Customer Responsibilities

- Assign a single Point of Contact (PoC) that will interface with Adtran for project coordination, resource scheduling, access, decision making, and information required to complete the work described in this SoW.
- Maintain a partnering relationship with the Adtran Project Manager to achieve project objectives and complete deliverables within the framework of the overall project SoW.
- Respond promptly to all inquiries and/or escalations regarding project.
- Participate in project meetings.
- Provide detailed physical and logical design documentation for the Core network.
  - A detailed CIQ will be provided to the customer to gather necessary demarcation information.



- Provide Adtran with specific system access, as required. All SDX shelves are remotely accessible via VPN, or ADTRAN approved access method, outlined below.
  - Provide systems access (Login and Password credentials) to ADTRAN personnel. Once access is established, Customer has responsibility to maintain access in accordance with ADTRAN personnel. VPN access is required.
  - ADTRAN will allow five business days to get the VPN access request started.
- Customer is responsible for providing all 3rd party materials as per the Adtran design and BOM i.e. fiber management systems, patch panels, fiber jumpers, etc. unless Adtran is contracted to furnish and install these components
- The Customer will be responsible for providing and powering a fuse panel for the SDX to be terminated to. That fuse panel is assumed to be in the same or an adjacent bay as the SDX with sufficient capacity for the addition of the SDX.
- The equipment's mounting location should be in place with available relay rack space, all cable management, power and fiber placed and spliced in order to support new SDX connectivity.
- Core deployment (switch/router paths) should be pre-provisioned to support Data and Voice and video prior to ADTRAN deployment engineers arriving on site.
- All fiber from site to site should be in place and tested and be available and ready to connect devices for onboarding throughout the network.
- Customer may propose changes to Services or Deliverables by providing appropriate advance notice for all changes to the Adtran PM. Adtran will use commercially reasonable efforts to respond with a detailed written estimate of the modification to the schedule or compensation for the Services or Deliverables within 5 business days. No change will take effect until both parties provide written approval of an amendment to the Order, however, Adtran will continue to provide Services and Deliverables as specified in the SoW until the change becomes effective, unless otherwise directed by Customer in writing.

#### **4 – Change Order Process**

- Job Change Orders may be required as the Services team develops, implements, and delivers services for customers, or the Customer may propose changes to Services or Deliverables. Change orders may be classified as billable or non-billable:
  - **Non-billable JCOs**- are typically items that are created through no fault of the customer and therefore ADTRAN Services would not pursue financial reimbursement from the customer. ADTRAN Services generally absorbs the cost for non-billable JCOs.
  - **Billable JCOs** -are typically items that are created due to some factor controlled by the customer and have a financial impact on the Services rendered. Services will typically negotiate payment with the customer for billable JCOs, but the Project Manager may choose to absorb a billable JCO if so desired.
    - The Project Manager will provide the scope and price for the JCO to the customer and request approval from the customer to move forward with rendering the services associated with the JCO.

## **5 – Assumptions**

- Travel costs for all On-Site work within this scope will be included in the quote.
- Any issues the Adtran Project Manager identifies as being issues related to the customer or its vendors, will be escalated to the customer PoC for resolution.
- Customer delays and/or customer changes in SoW could result in billable change orders.
- Scope changes or additions may delay the project and drive project schedule modifications and additional charges.

## **6 – Exclusions**

- ADTRAN shall not be responsible for any additional provisioning, maintenance, or other activities outside this SOW that may be discovered throughout this service's engagement. Additional services will be quoted upon request.
- Management of project responsibilities and deliverables assigned to the customer or its vendors.
- Implementation or installation of products for which there is no installation order or for those products not described in the Statement of Work, including labor, hardware, cables, etc.
- Troubleshooting or managing third party vendor issues
- Services made necessary by failures related to misuse, neglect, accident, alteration, modification, or willful or negligent acts by the Customer or other parties beyond the control of Adtran
- Correction of existing faults, defects, or workmanship issues identified as part of this project. Issues requiring correction, including troubleshooting, are not included as part of this services SoW. Adtran can provide a separate quotation on a Job Change Order (JCO) if requested, for any additional services need to correct the existing issue(s)
- Equipment not included in the Bill of Materials, or the installation of equipment not included in the Bill of Materials to which the equipment is mounted (unless specifically included in the Statement of Work)
- Optimization or troubleshooting of the End-User's network or applications
- Additional services not described in this scope of work can be quoted on request.

## **7 – Additional Terms and Conditions**

- Installation Acceptance and Labor Warranty
  - The system will be considered "in service" when it has been physically installed, configured, and is capable of passing the Customers traffic. At this point ProStart will notify the appropriate project stakeholders via email that the system is in service. This notification initiates the 14-calendar-day installation labor warranty, during which ProStart will make configuration adjustments based on written requests to fine-tune the network parameters, provided remote access is available. The ProStart PM will review these requests and schedule the changes provided they are within the scope of what

was purchased. If a Maintenance Plan has been purchased, then the plan will be activated on the same "in service" date as the beginning of the labor warranty. At the end of the labor warranty the installation will be deemed complete and accepted.

- The pricing contained in the accompanying quote is an offer for sale valid for 90 days unless otherwise stated.
- Unless the customer has a separately negotiated written agreement with ADTRAN that specifically applies to this order, the customer's order will be subject to and governed by ADTRAN's standard terms and conditions of sale set out in full at <http://portal.adtran.com/web/url/cts> ("ADTRAN Terms").
- The customer's acceptance of this offer is expressly limited to ADTRAN Terms and the terms of this quote, and notice of objection to and rejection of any additional or different terms is hereby given.
- In the event of a conflict between ADTRAN Terms or any negotiated written agreement, on the one hand, and this quote, on the other hand, the terms of the quote will govern.
- Any terms and conditions set forth in the customer's purchase order or any other correspondence that are in addition to, inconsistent or in conflict with ADTRAN Terms, together with the terms of this quote, will be of no force or effect, unless specifically agreed to in a writing signed by ADTRAN that expressly references such terms.
- In the event this project should be cancelled, ADTRAN reserves the right to charge for all expenses, furnished materials, engineering, and installation services completed up to the date of cancellation.





# References and Contact Information

ConnectSuperior Fiber Network Equipment and Services RFI

Adtran Response No. 1236550

October 3, 2023

## **Adtran PROPRIETARY**

**This document is the property of Adtran Inc. Any duplication, reproduction, or transmission to unauthorized parties without the permission of Adtran Inc. is prohibited.**

**This document represents a proposed solution for a specific application. Specific requirement implementation is conditional depending on customer approval of the solution and a mutually agreed upon development schedule.**

**Copyright © 2023 Adtran Inc.**

**ALL RIGHTS RESERVED**

The **City** requires sufficient corporate, financial, and reference information to adequately assess the qualifications of the **Seller** to sell, install, and support the **Proposed Solution**. The reference information will be used by the **City** to differentiate between **Sellers** with similar **Proposed Solutions**, and shall be provided in a separate document including the following information:

Corporate Information

The **Seller** shall provide an overview of their corporate structure. The overview should address the following specific items:

- Name, address, and contact information of the Company and representative

[Adtran, Inc.](#)

[901 Explorer Boulevard](#)

[Huntsville, AL 35806](#)

[Matt Huovinen](#)

[218.329.2632](#)

[Matt.huovinen@adtran.com](mailto:Matt.huovinen@adtran.com)

- Company History and Formation

[Adtran was incorporated in 1985 and began operation in 1986 in Huntsville, Alabama.](#)

[On August 30, 2021, we announced our now executed business combination with ADVA to create a global leader in scalable, end-to-end fiber networking solutions for communication service providers, enterprises and government customers. The merger unites our fiber access, fiber extension, and subscriber connectivity technology with ADVA’s innovation in data center interconnect solutions for large enterprises, business Ethernet and network synchronization. Both companies are pioneers in open, disaggregated solutions with a shared vision for the future of fiber networking. Our combined business will offer a comprehensive portfolio for providing homes, businesses and 5G infrastructure with scalable, secure and assured fiber connectivity, paired with cloud- managed Wi-Fi connectivity and SaaS applications. Together we will be a trusted supplier to more customers worldwide, meeting new requirements, optimizing network performance and improving customer experience.](#)

- Ownership (Public or Privately Held)

[Adtran is publicly held, traded on the NASDAQ exchange, symbol ADTN](#)

- Number of Employees

[Adtran, Inc. had 3,307 full-time employees as of December 31, 2022](#)

- Organizational chart of the management and implementation teams for a proposed project

## **ADTRAN Executive Team**

### **Darrell Brown: Vice President Sales – Alternative Service Providers**

[Darrell Brown began his career with ADTRAN in January of 2001 when he accepted a role in a personnel development program, intended to prepare him for a role in the product management organization. Soon after joining ADTRAN, a setback in the telecommunications market resulted in](#)

Adtran Proprietary and Confidential

the dissolution of the development program; Darrell was nonetheless able to quickly advance within the organization. He held positions in documentation, product support engineering and sales & solution engineering before accepting the product management challenge in 2004. His initial PM responsibilities centered around our Total Access 3000 platform. In early 2007, Darrell earned responsibility for the Total Access 5000 and was subsequently promoted to senior product manager in 2008. In 2009, he was promoted to product line manager, where he had responsibility for both the Total Access 3000 and the Total Access 5000. In 2012, Darrell accepted a promotion into the role of Director of Product Management for Carrier Networks, where he had responsibility for all CN products. Then, three years later, in 2015, he was given the opportunity to move into a more customer facing role, leading the North American Sales Engineering team. Darrell found that he thrived on helping solve customer problems and providing unique solutions to their challenges. Thus, in 2018, he accepted a role in the newly formed National Accounts team so that he could be even more directly involved with his customers' success. In October of 2019, Darrell accepted another offer for increased responsibility and was promoted to Strategic Sales Director, where he assisted with ADTRAN's overall strategies within the electrical distribution company market sector, along with managing a three-state territory and his legacy national accounts. In September of 2021, Darrell accepted a promotion to Vice President of Sales where he became responsible for the strategy and performance of the sales team to which he was previously a member. He continues to work in this capacity and, together with his team, has assisted 105 companies launch broadband services with Adtran's solution set. Prior to ADTRAN, he served as an Electrical Distribution Engineer at both Georgia Power Company and Alabama Power Company. Darrell holds a Bachelor of Science in Electrical Engineering and a Marketing degree from The University of Alabama.

## **ADTRAN Project Team BIOS**

### **Matt Huovinen: Strategic Sales Director**

Matt started in Telecom in 2000 when he helped build an ISP from the ground up. Through those 8 years he held several technical positions and assisted with migrations, acquisitions, and growth. Matt spent several years with an electronics manufacturer as a Sales Engineer and then a Territory Manager. Matt also spent several years in distribution selling everything from Central Office to OSP. These roles allow a wide perspective of the trials that it takes to build an internet provider.

### **Keith Nicoulin: Sr. Sales Engineer ASP**

Keith is a 25-year veteran of the Telecom Industry. Keith's experience transcends all facets of the Telecom Access Industry. Keith's career began at Verizon where he started as an apprentice cable splicer and grew into multiple more responsibility rolls over a 9-year span. Keith's career then progressed into senior sales engineer rolls at Actelis and Smart RG providing support for pre/post and support engineering as needed to enhance his customer's success. In 2018 Smart RG was acquired by Adtran where Keith career has grown to his current role of supporting Adtran's new Alternative Service Provider Customers with designing, providing technical guidance and insuring successful first customer turnups.

# ADTRAN Professional Services Team

## **Sean Stacy: Manager Broadband Deployment**

Sean's career encompasses 25 plus years in the Telecom Industry. Sean's experience transcends all facets of the Telecom Access Industry. Sean's career started as an installer for Falcon Communications installing Siemen's DCO (Digital Central Office) and Nortel DMS-10. Sean was a Network Engineer for Lumen supporting Access DSLAMs, ATM, Frame Relay, Fujitsu 9500, Ciena L2 Switches & Nokia 7750 Routers. Sean has been with ADTRAN as a Lead Engineer and now Manager for 6+ years.

## **Craig Dupree: Manager Network Engineering**

For more than a decade, Craig has worked in a variety of roles within the telecommunications industry. After joining ADTRAN seven years ago, Craig quickly moved into a leadership position where he currently manages the engineering team responsible for network engineering, both ISP and OSP. Craig holds a BS of Electrical Engineering from Kennesaw State University and currently resides in Northwestern Georgia.

## **Wayne Bernstein: Program Director, Professional Services**

Wayne's career encompasses 40 years in the telecommunications industry with Nortel, Ericsson, Sprint, and Adtran. Wayne has 30 years managing large complex projects within the wireless sector, including greenfield network build outs, network deployments, and upgrades, both nationally and internationally. Expert in project and operations management, blending hands-on project leadership with strategic planning, P&L management, and KPI improvement. Managed large, diverse cross-functional implementation teams consisting of Project Managers, Engineers, Operations, Construction, and Project Support professionals.

## **Lou Windsor: Program Manager Professional Services**

An accomplished leader with 27 years of experience in telecommunications and IT project, program, and portfolio management. He has exhibited his expertise in all facets of project lifecycles for high-profile organizations, including Nissan North America, Trane, and Ingersoll Rand. Currently manages a team of project management professionals and applications engineers who are focused on consistency and quality in all aspects of project execution and customer care.

## **Angela Peratta: Project Manager**

Angela's career encompasses 25 plus years of progressive experience working with a broad range of high-profile clients in the Service Provider Market. Angela has a proven ability to work cross-functionally to develop and evaluate solutions to a wide range of problems. Angela designs methodical approaches to solve a multitude of issues from a tactical, strategic, analytical, and operational perspective and excels in defining, organizing, and executing multifaceted projects within time and budgetary constraints.



### Implementation Experience

**ConnectSuperior** will operate in a competitive marketplace as an open-access network, therefore the **Seller's** experience implementing and supporting **open-access** networks will be crucial to the successful launch and ongoing operation of **ConnectSuperior**. To this end, the **Seller** shall provide a brief summary of their experience implementing and supporting carrier-class open-access networks. The summary should address the following specific experience:

- Implementations of municipal and/or commercial **open-access** networks
- Implementations of similar network architectures
- List of certifications relative to the **Proposed Solution** held by the implementation team
- List of partner certifications relative to the **Proposed Solution** held by the **Seller**

**Sellers** with specialization in the proposed equipment manufacturers' service provider architecture are preferred. Copies of formal manufacturer-conferred certifications including the certification name, description, requirements, and date of award/renewal should be provided in the **Seller's** response.

Adtran is the manufacturer of the proposed solution. Adtran has a Global Services team that has a strong history of providing technology expertise in engineering broadband solutions, installing, provisioning and maintaining networks and have proven to be valuable partners to our customers as they complete node deployments. Our global presence helps to provide services operations around the world including the Americas, EMEA, and Australia. With an abundant number of Services Professionals and over 175 Service Partners around the world we maintain a scalable workforce to take on a multitude of projects. We have proven our capabilities with delivering over 75,000 network implementation projects for our customers.

The **Seller** shall submit a list of three (3) **open-access** references who have deployed similar architectures within the last five (5) years. The reference information shall include the company name with dates of implementation along with the name, address, and phone number of the individual(s) that may be contacted at the company. **Seller** shall omit all homogenous enterprise IT deployments (i.e., private corporate-centric networks) from their response and references.

### **Openreach**

Openreach is one of Adtran's largest examples of open-access, currently passing 12 million homes with a build plan to get to 25 million by 2027. Please refer to the Press Release: [Openreach connects first customer on Adtran's gigabit-capable GPON solution](#)

### **NBN**

Adtran has been a contracted strategic vendor to Australia's 100% government-owned National Broadband Network (NBN) since 2017, supplying broadband connectivity equipment into the Fibre-to-the-Curb (FTTC) footprint.

The NBN Co. was established in 2009 by the Commonwealth of Australia as a Government Business Enterprise (GBE) with a clear direction – to design, build and operate a wholesale broadband access network for Australia. The network is the digital backbone of Australia and is constantly evolving to keep communities and businesses connected and lift the digital capability of Australia.

NBN has chosen to connect communities and businesses with multiple broadband technologies including FTTP, FTTN, FTTC, HFC, Fixed Wireless and Satellite. Each of these solutions are set to evolve over time towards a predominantly 'full-fibre' network in the future. NBN Fibre to the Curb (FTTC) connections are

Adtran Proprietary and Confidential

used in circumstances where fibre is extended close to the premises, connecting to a small Distribution Point Unit (DPU), generally located inside a pit on the street. From there, the existing copper network is connected to the fibre to form the final NBN connection. To power the NBN FTTC service with electricity and provide the connection to the NBN network, a Network Controller Device (NCD) connection box is installed inside the home or business.

Adtran was awarded a 10 year supply contract in 2017 for the supply of DPUs into the FTTC footprint and in 2019 was awarded additional contract supply of the NCD or Customer Premise Equipment (CPE). The FTTC footprint spans various regions across the eastern seaboard of Australia and connects at least 1.4 million premises. During the course of the contract, Adtran has become a trusted strategic partner within a multi-vendor supply environment involving extensive cooperation with NBN and competing vendors for interoperability. To date, Adtran has supplied more than 180k DPUs and more than 330k NCDs to NBN and during 2024 will become the primary supplier of DPUs to NBN for the foreseeable future.

Adtran's engagement with NBN has required a deep understanding of the wholesale Layer 2 network construct and demanded specific development of hardware and software to support the needs of wholesale service models. It also places Adtran within a core group of trusted vendors who can be relied upon to continue supporting the network and play a role in future augmentations as it evolves towards a full-fibre gigabit capable network of the future.

### **Contactable References**

#### **Netomnia**

Contact: Feka Samakuva  
email: [feka@netomnia.com](mailto:feka@netomnia.com)

Netomnia is a wholesale fibre operator covering over 500K homes throughout the U.K. They have invested in our SDX6330 and SDX6320 OLTs along with our 62x and 63x ONTs.

#### **Connect Fibre**

Contact: Mark Cornish  
email: [mark@connectfibre.co.uk](mailto:mark@connectfibre.co.uk)

Connect Fibre offer both wholesale and retail services serving communities in the eastern part of the U.K. They are using the SDX6320, SDX6330 and SDX8305 OLTs and 62x ONTs and MCP.

#### **F&W Networks**

Contact: Oriol Riba  
email: [oriol@fwnetworks.co.uk](mailto:oriol@fwnetworks.co.uk)

F&W is a wholesale only operator serving communities in the around the Buckinghamshire and Oxfordshire areas. They predominantly use the TA5K with 62x ONTs along with MCP.